

Date of Purchase \_\_\_ / \_\_\_ / \_\_\_  
Lot Number:



**Look** inside for Assembly Manual

Check us out!



Littleseedskids.com

# 2530015COM

## 3 Drawer 1 Door Dresser



Keep this Assembly Manual for future reference.

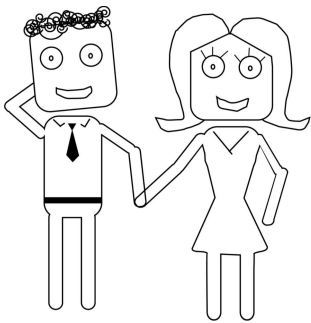
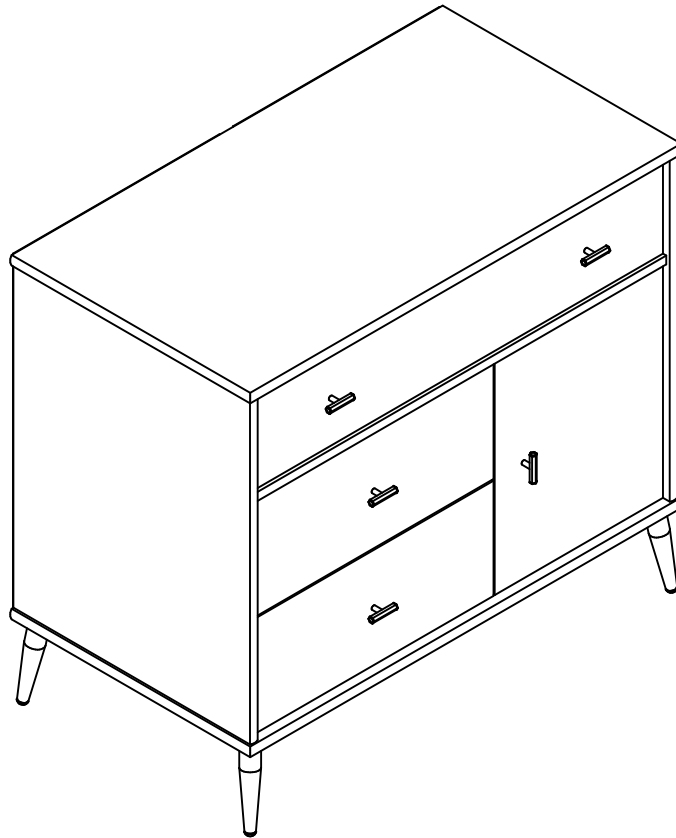

Two adults recommended for assembly

Las traducciones en español se encuentran al final de este manual.

Vous trouverez les traductions en français à la fin de ce manuel.

## Secure Your Furniture

Keep your home and family safe with the wall anchor kit that is included with the product.

Serious or fatal crushing injuries can occur from tipping furniture.

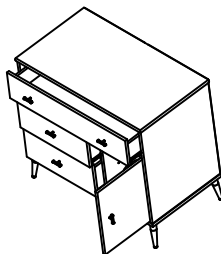

**WARNING:** Manufacturer assumes no liability for improper installation or excessive loads placed on screws or bracket. This wall anchor is not a substitute for proper adult supervision.

2

Do NOT return this product.

For missing or broken parts

- Visit [littleseedskids.com](http://littleseedskids.com)

- Call 1-800-489-3351

Follow little seeds on



This product is not intended for commercial use.



---

## Do NOT return this product!

Contact our friendly customer service team first for help.

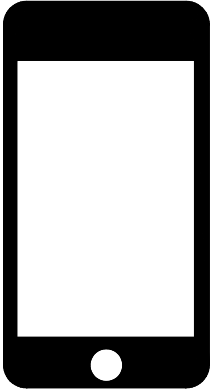

### Call us!

1-800-489-3351  
Monday-Friday  
9am - 5pm CST



### Assembly Tips



Visit [littleseedskids.com](http://littleseedskids.com) to view the limited warranty valid in the U.S. and Canada.

---

## Helpful Hints

PEOPLE NEEDED FOR ASSEMBLY: 1-2

---

- Open your item in the area you plan to keep it for less heavy lifting
- Identify, sort and count the parts before attempting assembly
- Compression dowels are tapped in with a hammer
- Slides are labeled with a **R** (right) and **L** (left) for proper placement
- Make sure to always face the point on the top of the Cam Lock towards the outer edge
- Use all the nails provided for the back panel and spread them out equally
- Back panel must be used to make sure your unit is sturdy
- Do NOT use harsh chemicals or abrasive cleaners on this item
- Never push, pull, or drag your furniture

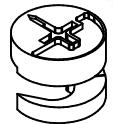
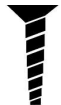



Please Note:

You may need to lightly tap the wood dowels into the holes during your assembly process.

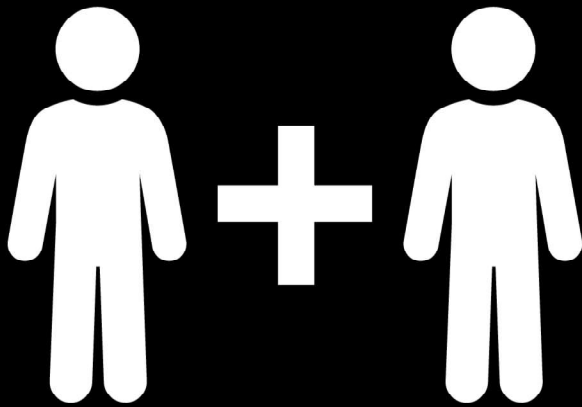
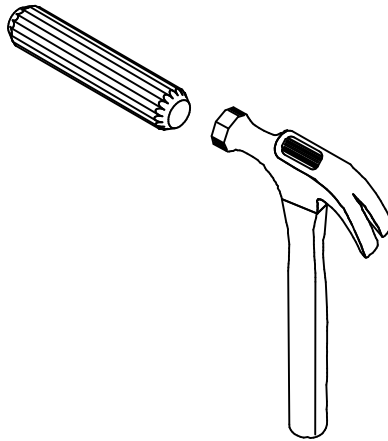

**2 PEOPLE NEEDED FOR ASSEMBLY**

**2 PERSONAS NECESITADAS  
PARA LA ASAMBLEA**

**2 PERSONNES NÉCESSAIRES  
POUR L'ASSEMBLAGE**

**CAUTION:** Failure to use 2 people for assembly could result in unit damage or personal injury.

**PRECAUCIÓN:** Si no se utilizan 2 personas para el ensamblaje, se pueden producir daños en la unidad o lesiones personales.

**ATTENTION:** Échec d'utiliser 2 personnes pour l'assemblage peut causer du dommage au meuble ou causer des blessures.



# Board Identification

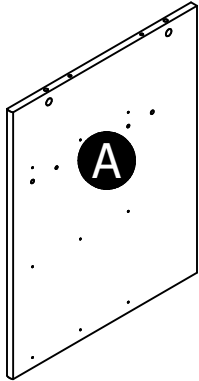

Left Panel  
32530015010

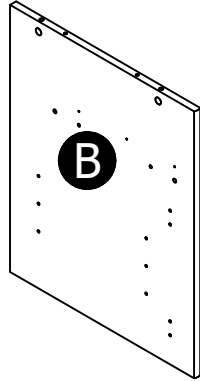

Right Panel  
32530015020

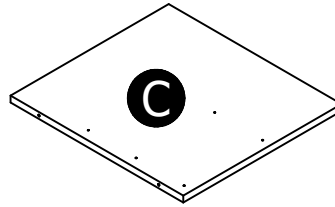

Partition  
32530015030

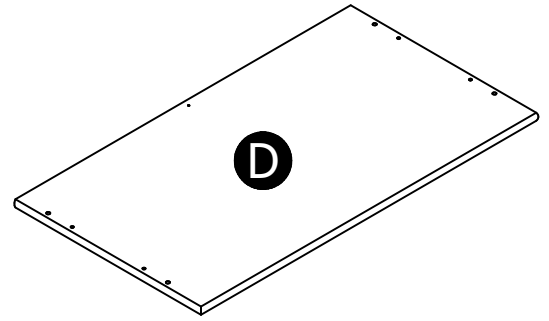

Top  
32530015040

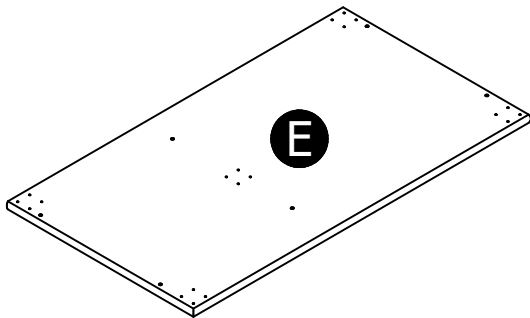

Bottom  
32530015050

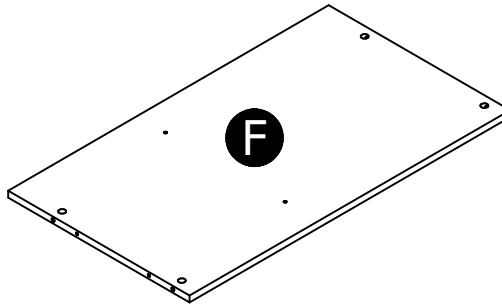

Shelf  
32530015060

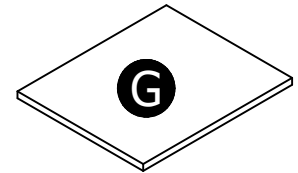

Adjustable Shelf  
32530015070

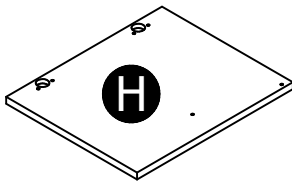

Door  
32530015080

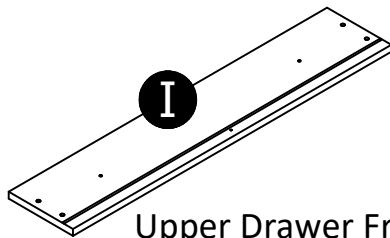

Upper Drawer Front  
32530015090

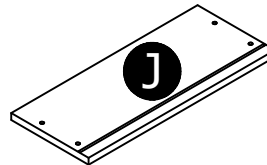

x2  
Drawer Front  
32530015100

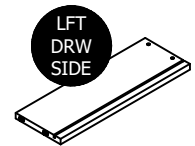

Left Upper Drawer Side  
39991120346510L

# Board Identification



Right Upper Drawer Side  
39991120346510R

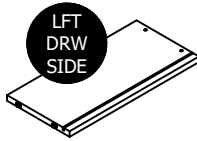

x2  
Left Drawer Side  
39991167346510L

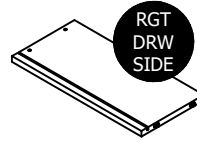

x2  
Right Drawer Side  
39991167346510R

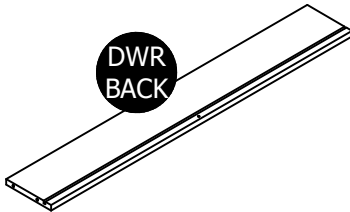

Upper Drawer Back  
39991120080518B



x2  
Drawer Back  
39991167045317B

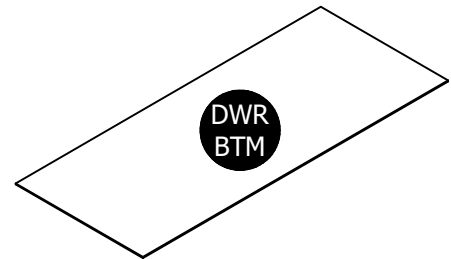

Upper Drawer Bottom  
39991340081610D

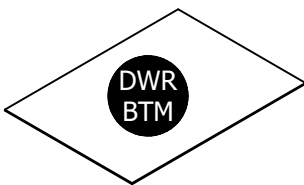

x2  
Drawer Bottom  
39991340046510D

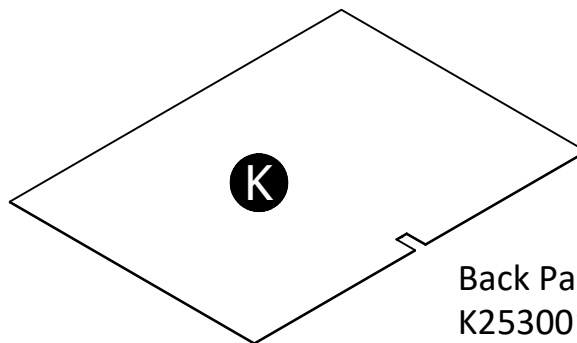

Back Panel  
K253001500

This piece is paperboard construction.  
It is not made from wood but is  
required for the assembly of your unit.

# Board Identification

This piece is paperboard construction. It is not made from wood but is required for the assembly of your unit.

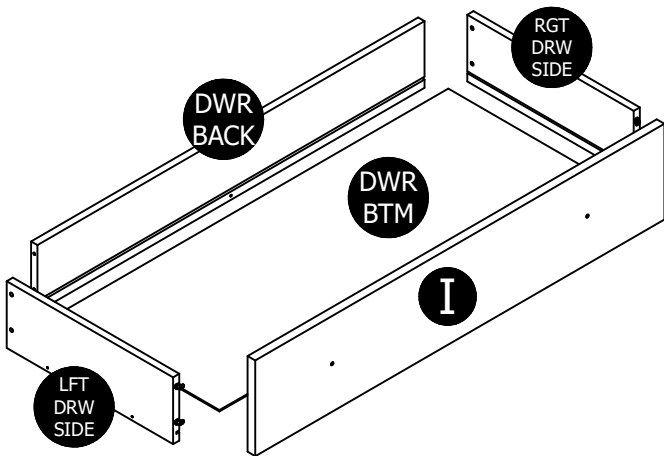
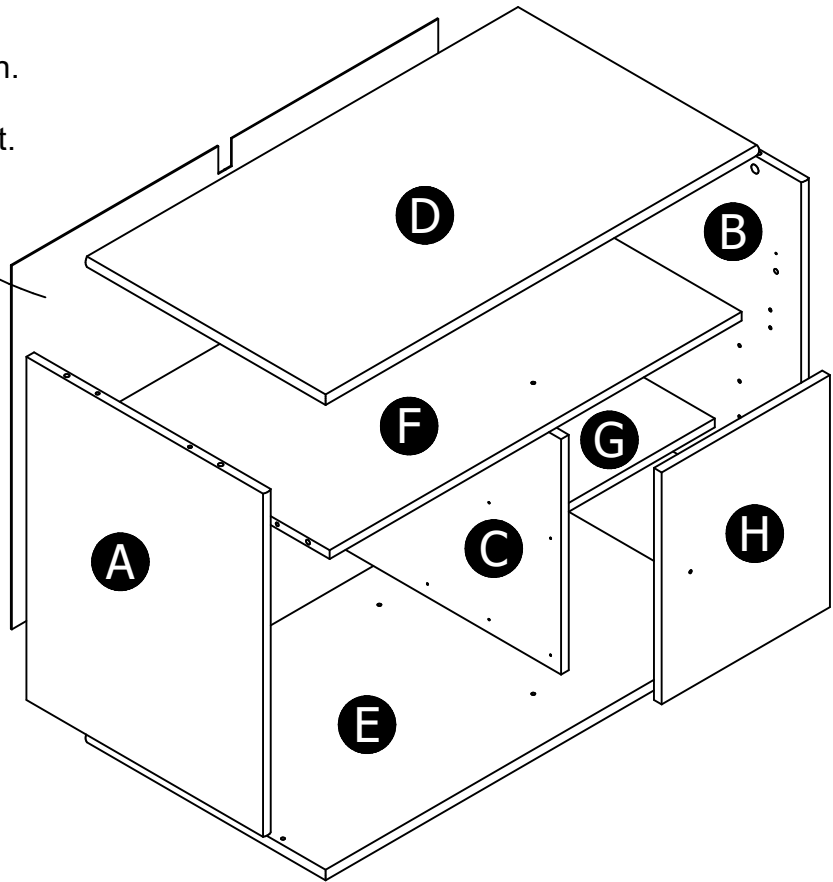

Upper Drawer

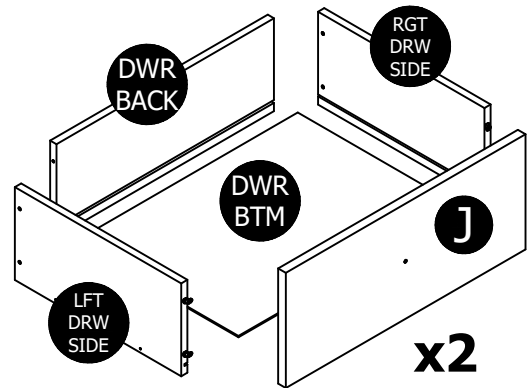

Lower Drawers

Please Note: Your model may contain extra hardware.

# Parts List

Actual Size

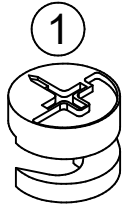

x8  
#A22700  
cam lock



x8  
#A22710  
cam bolt

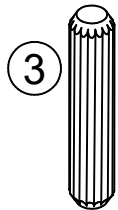

x8  
#A21670  
wood dowel

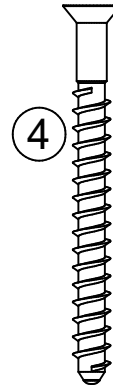

x8  
#A23030  
confirmat



x30  
#A11080  
7/16" flat head



x5  
#A17400  
7/8" truss head

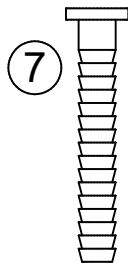

x12  
#A21975  
drive fastener



x2  
#A12120  
7/16" pan head

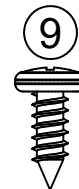

x20  
#A14220  
1/2" pan head



x1  
#A89370  
door bumper



x28  
#A21110  
nail

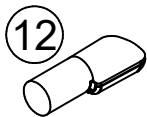

x4  
#A80250  
shelf support

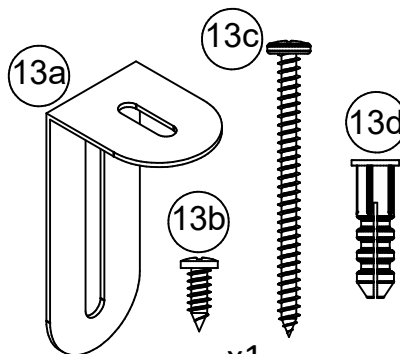

x1  
#A84050  
safety bracket kit

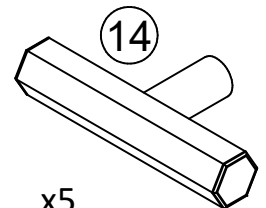

x5  
#A50170  
handle



# Parts List

Not Actual Size

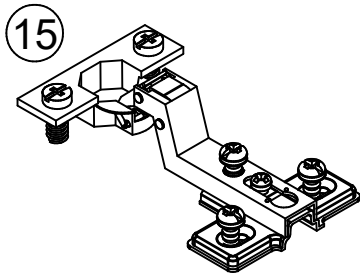

x2  
#A65640  
hinge

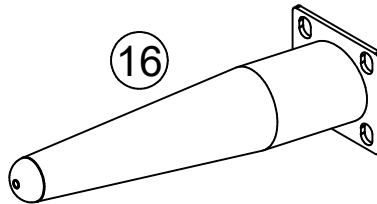

x5  
#A44680  
leg

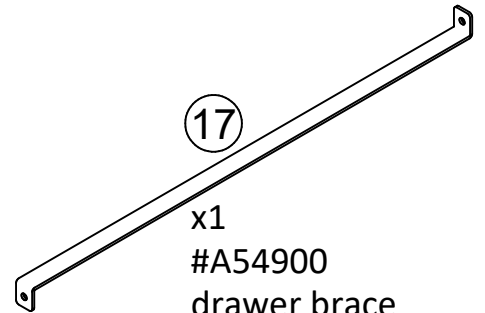



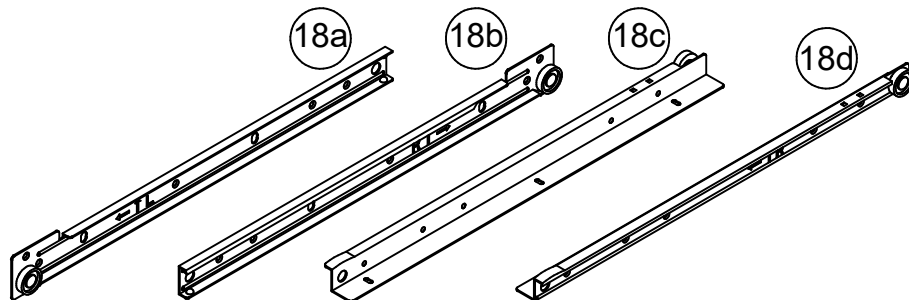





x1  
#A54900  
drawer brace

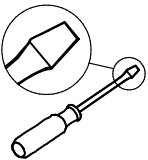

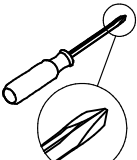
left cabinet member    right cabinet member    left drawer runner    right drawer runner

x3  
18 #A56770  
drawer slide package

# Before You Start

- 
 Read through each step carefully and follow the proper order
- 
 Separate and count all your parts and hardware  
Parts are labeled on the surface or edge of part
- 
 Give yourself enough room for the assembly process
- 
 Have the following tools: Flat Head Screwdriver, Phillips Head Screwdriver and Hammer

# Cam Lock Fastening System

This Cam Lock Fastening System will be used throughout the assembly process.

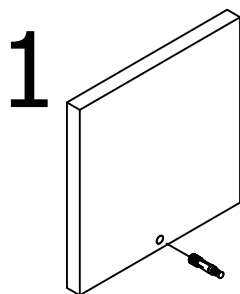

1 Press CAM BOLT into hole.

2

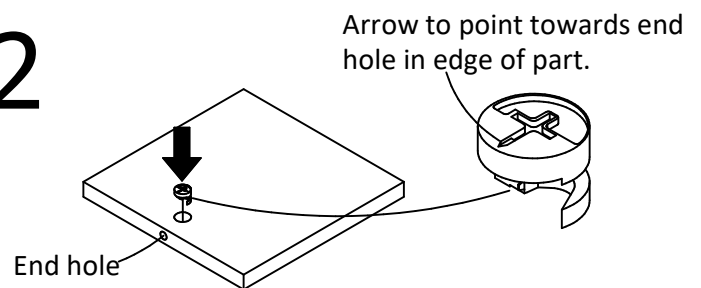

Press CAM LOCK into hole.

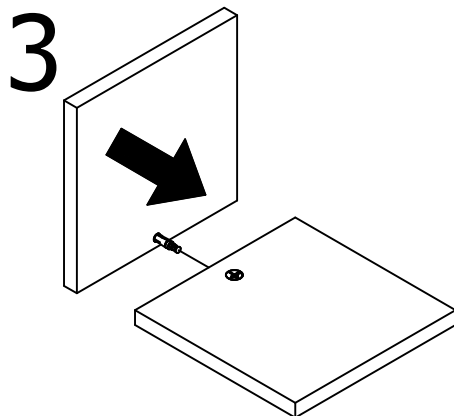

3 Press parts together so CAM BOLT inserts into edge hole.

4

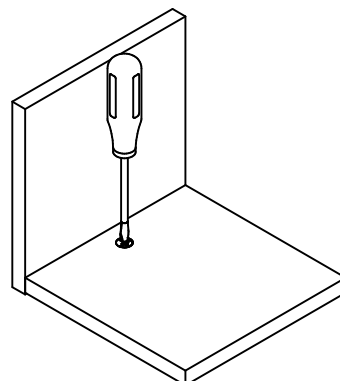

4 Using a screwdriver, turn the CAM LOCK clockwise to lock the CAM LOCK and CAM BOLT into their holes and fastening parts together.

# Step 1

Caution: If you are using a power drill or a power screwdriver for screwing, please be aware to slow down and stop when the screw is tight. Failure to do so may result in stripping the screw.

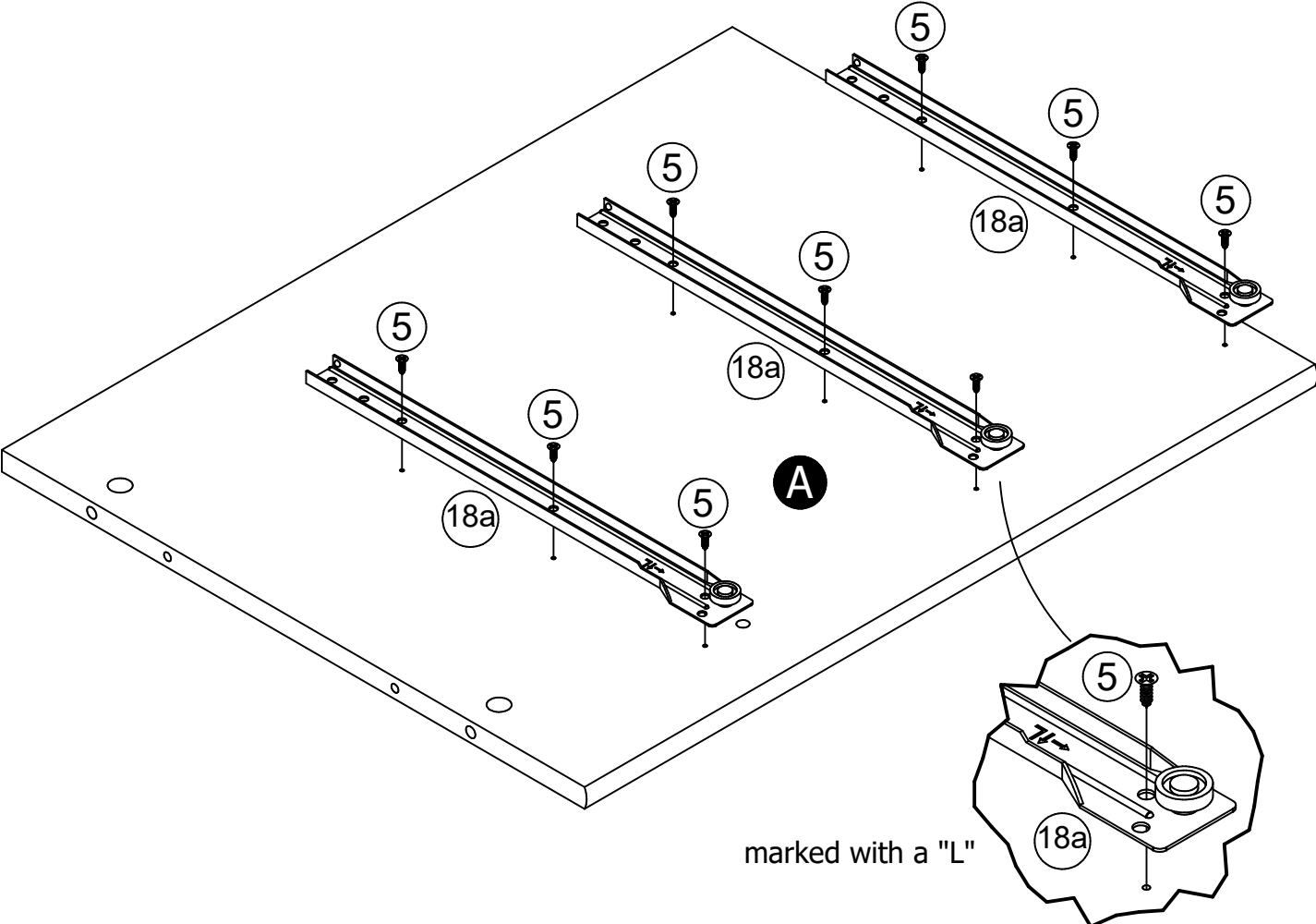
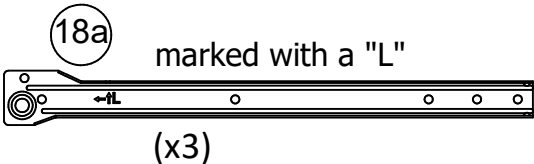
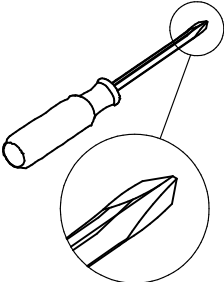

# Step 2

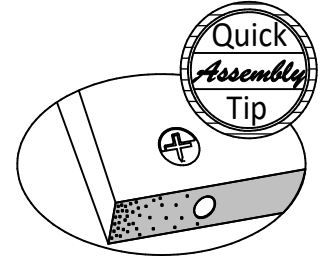
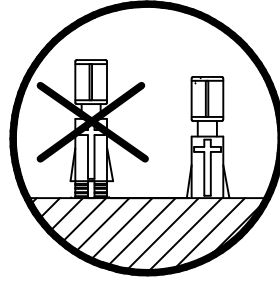
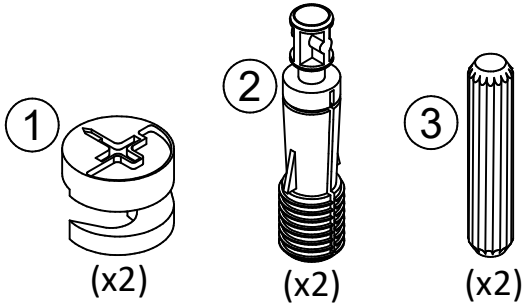

Proper orientation of CAM LOCK

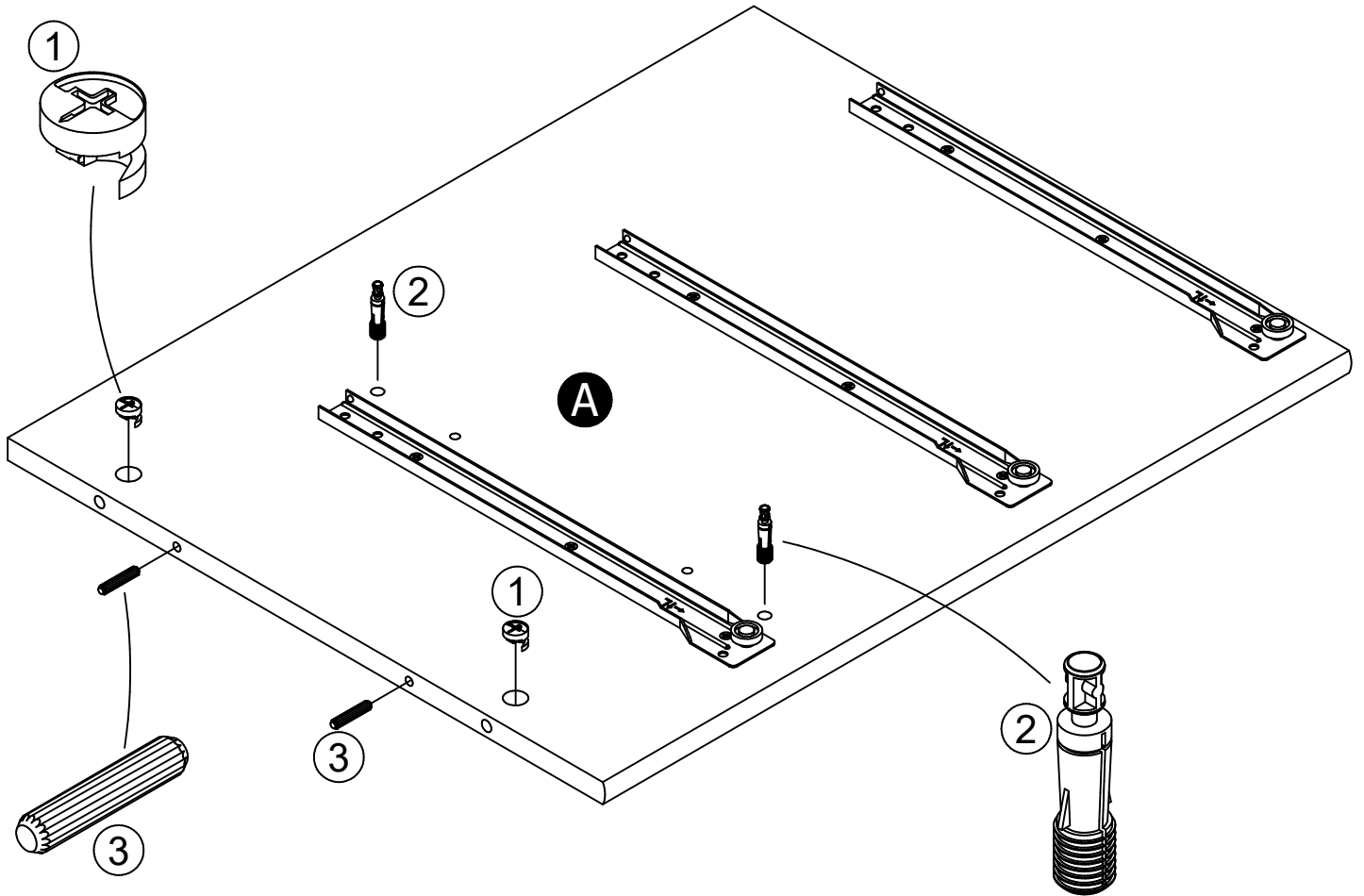

# Step 3

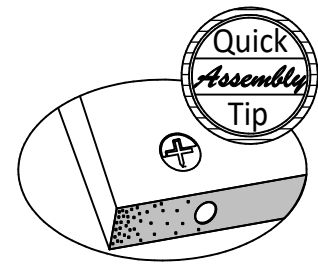
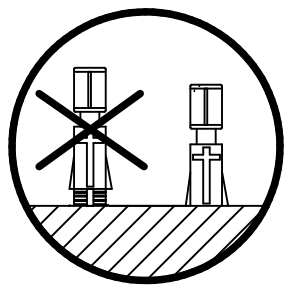
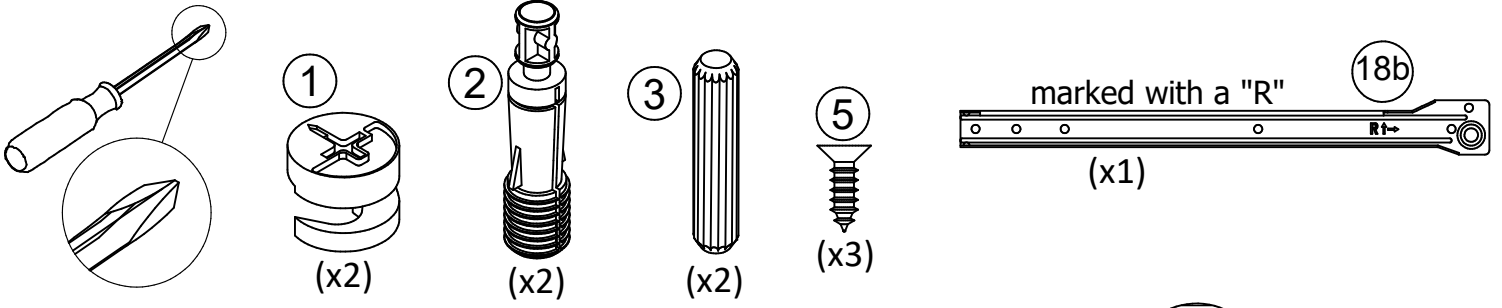

Proper orientation of CAM LOCK

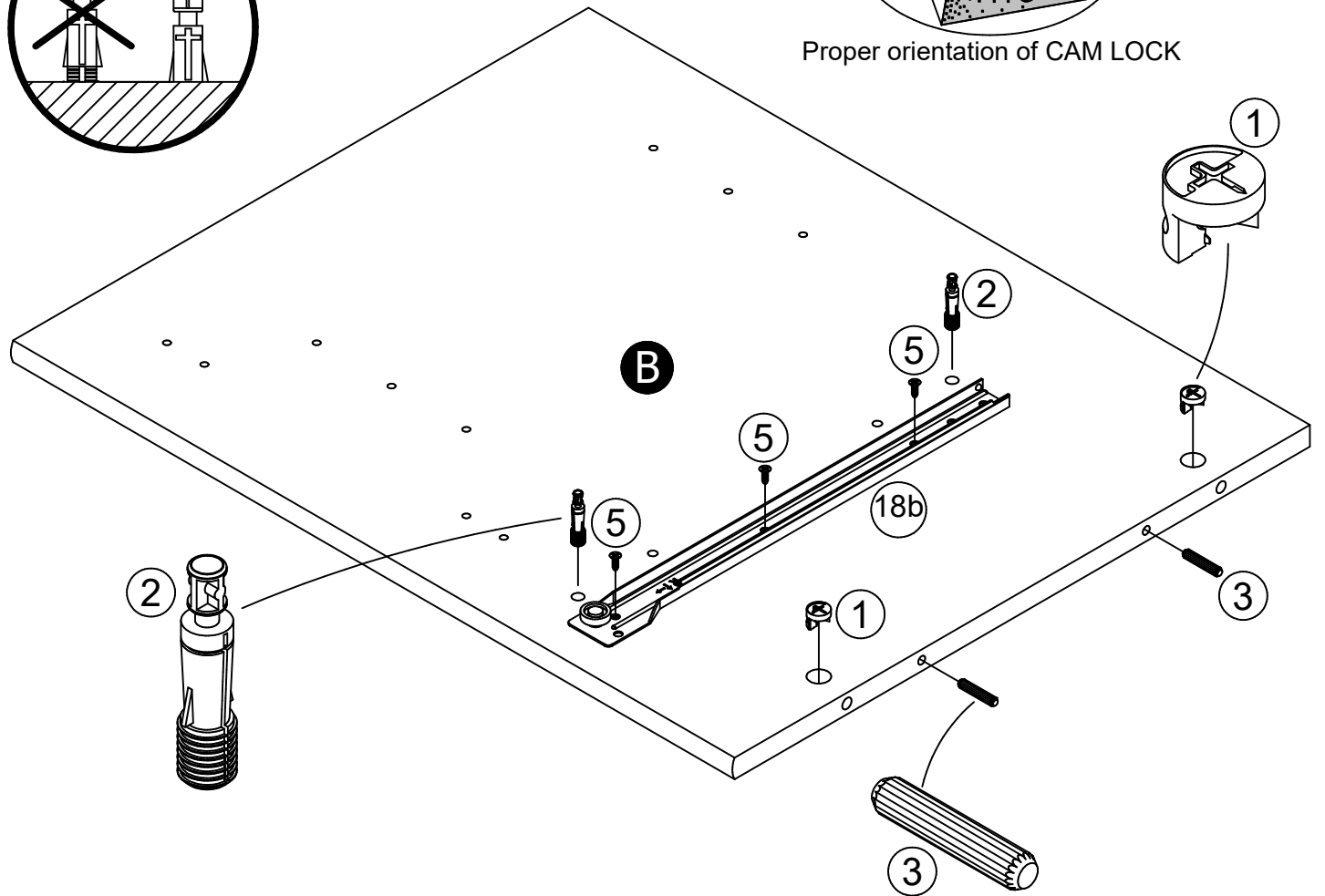

# Step 4

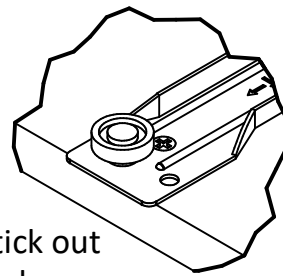
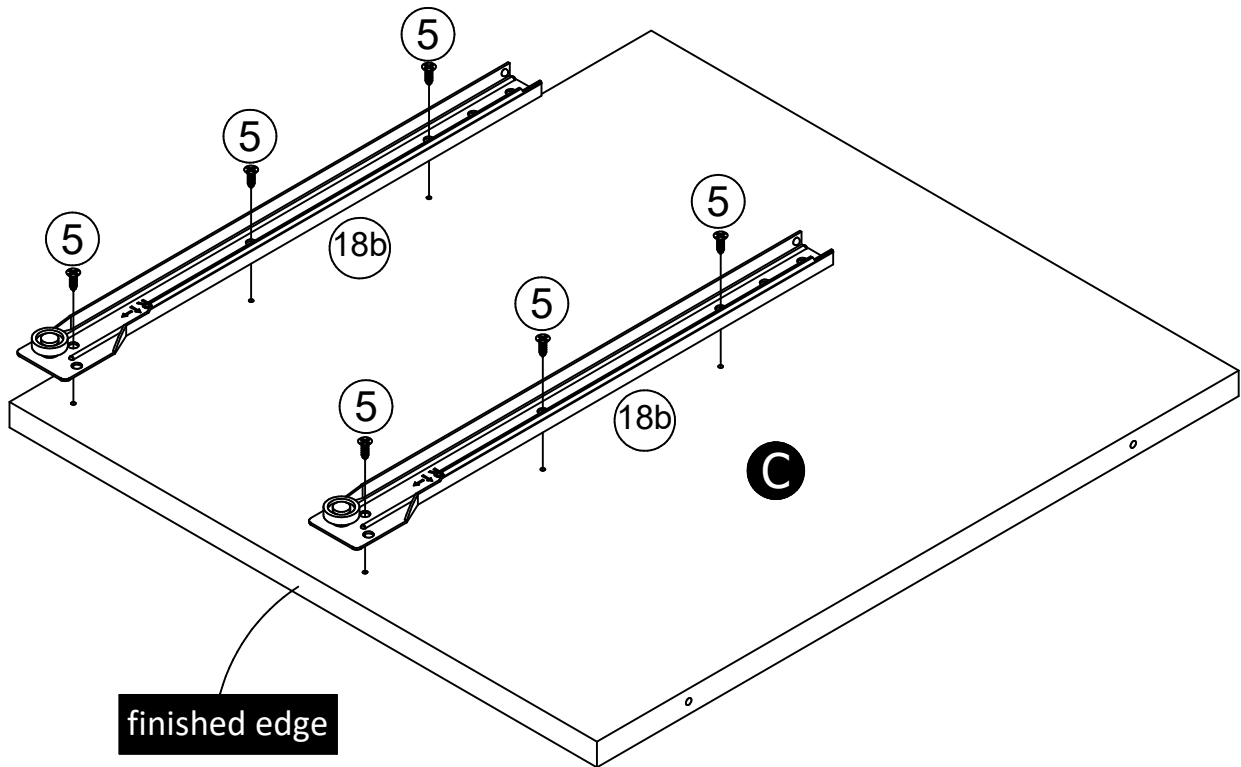
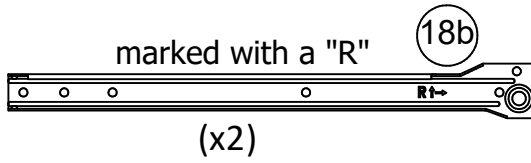
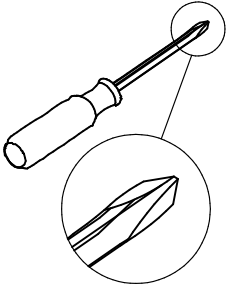

Note:  
Slides will stick out  
3mm from edge

# Step 5

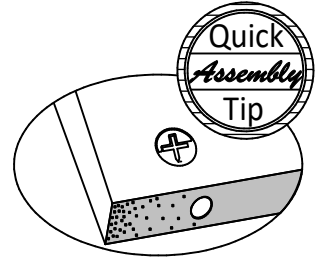
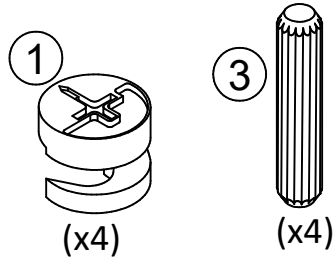

Proper orientation of CAM LOCK

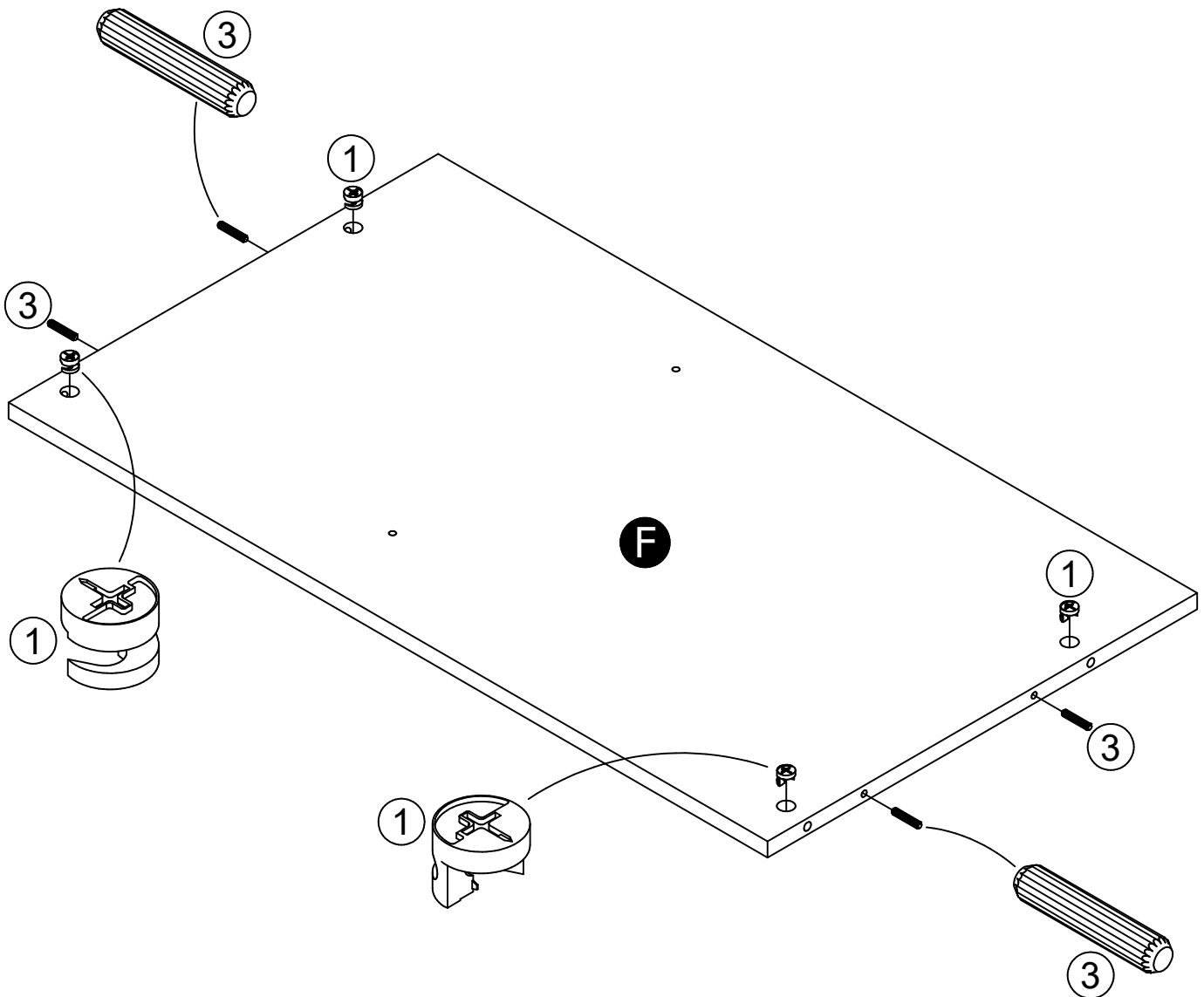

# Step 6

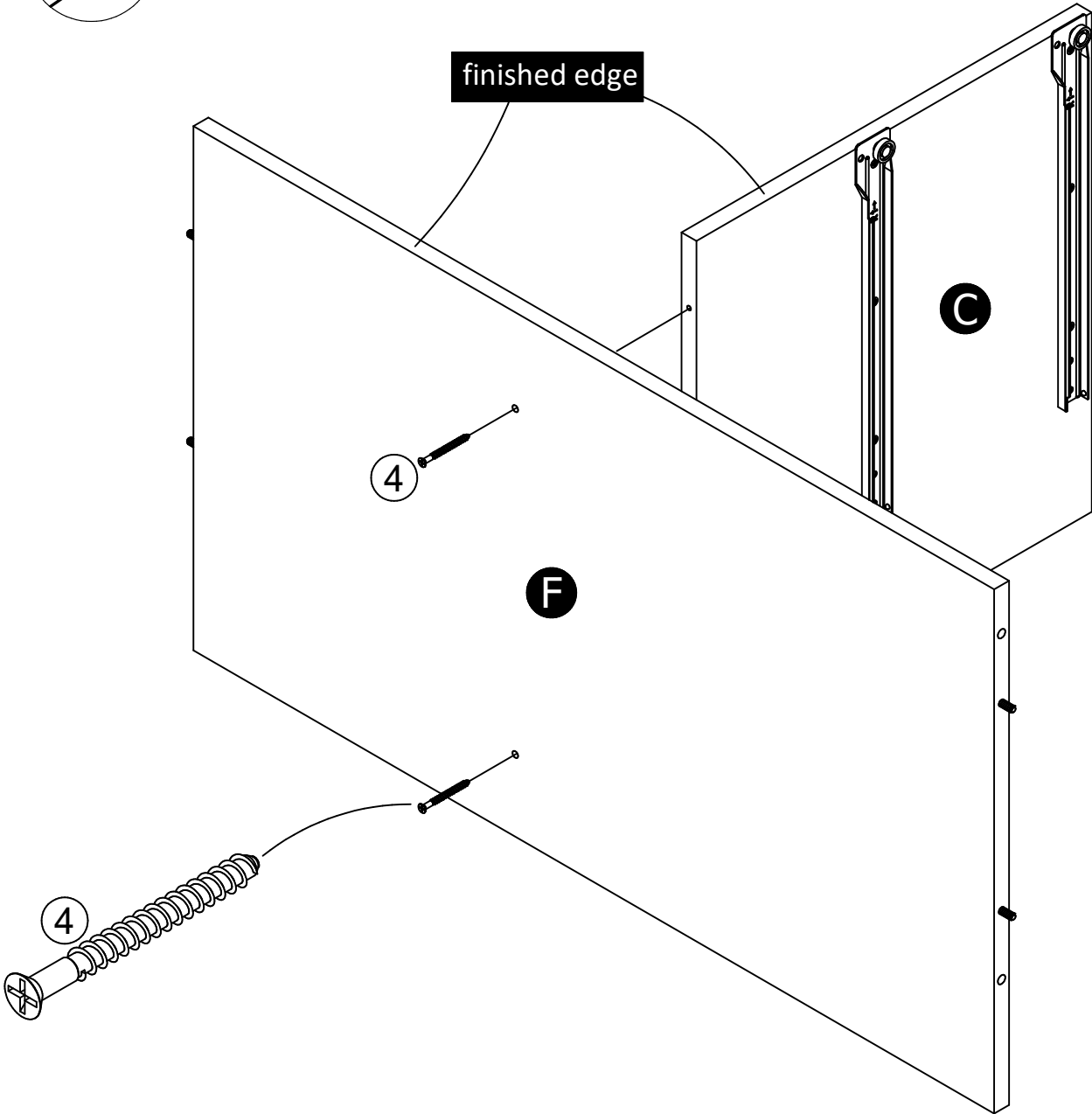
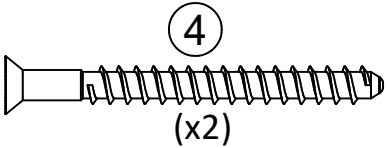
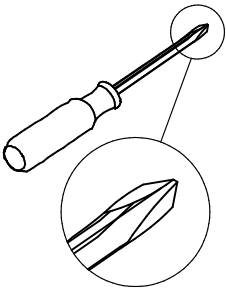



# Step 7

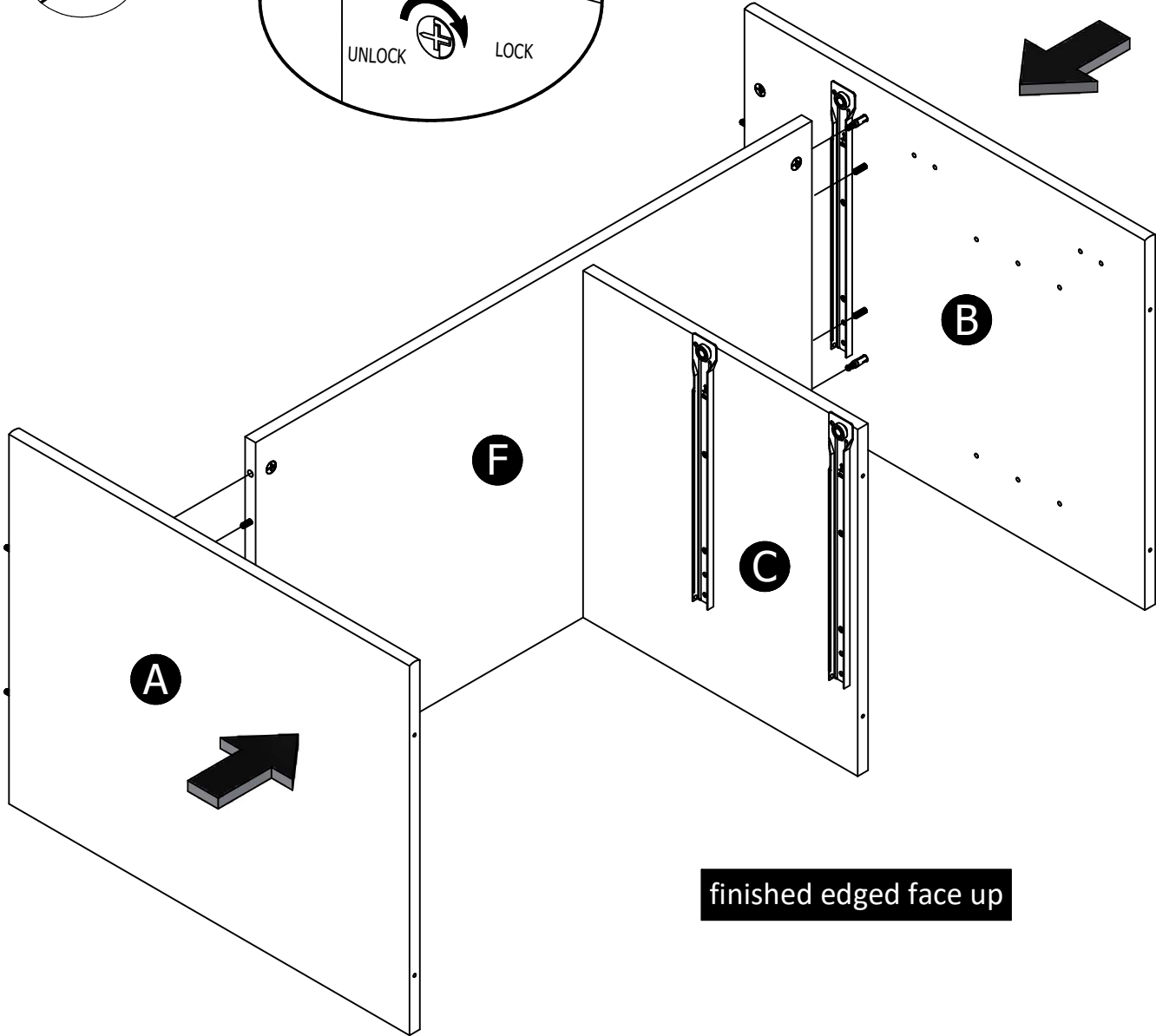
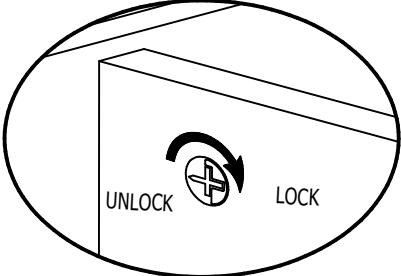
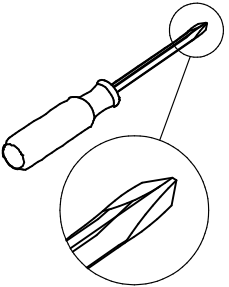

finished edged face up

# Step 8

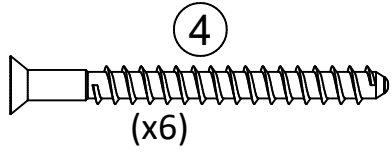
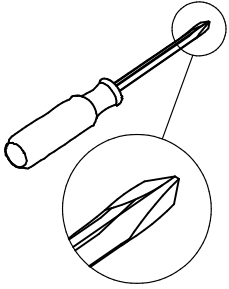

finished edged face up

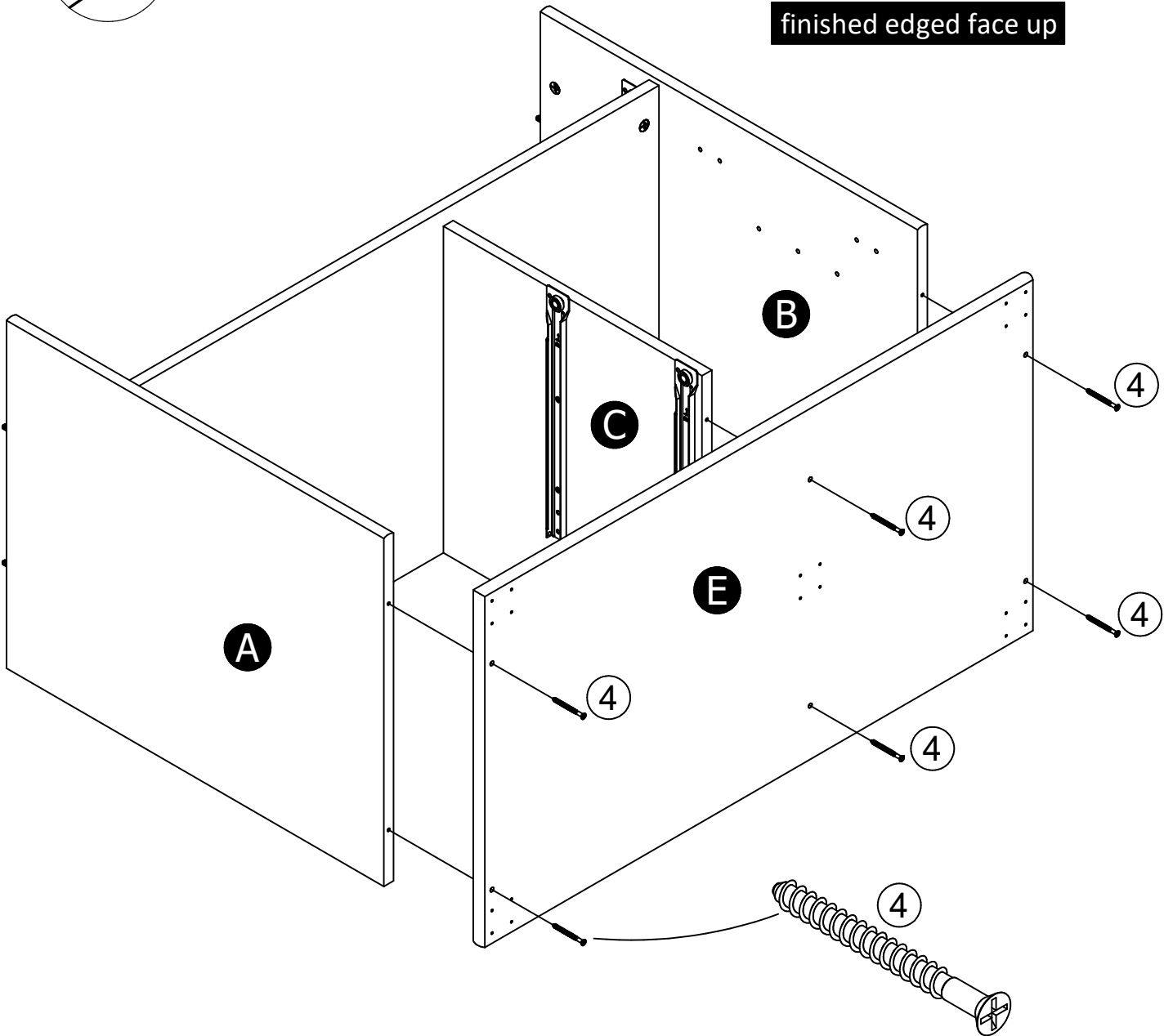

# Step 9

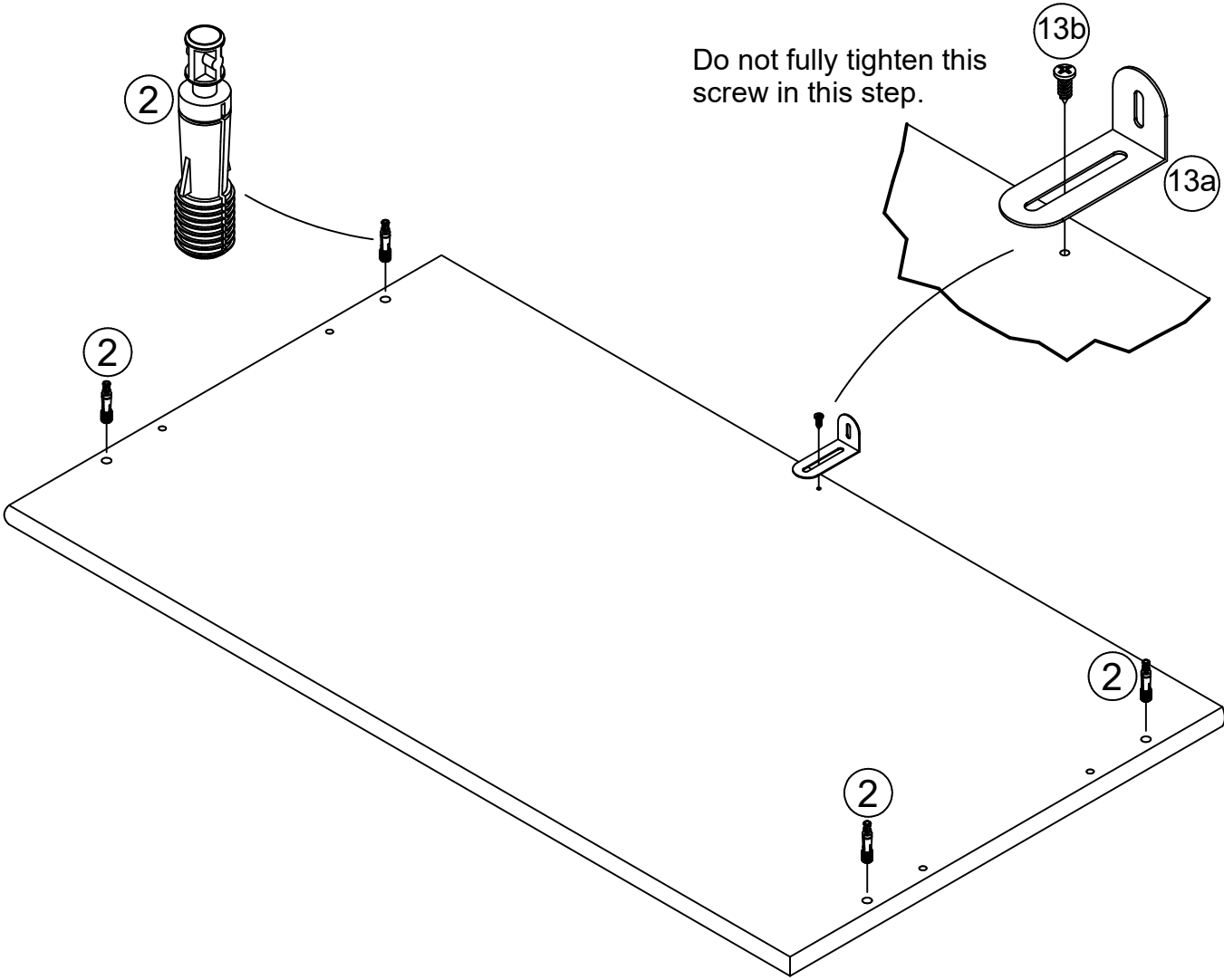
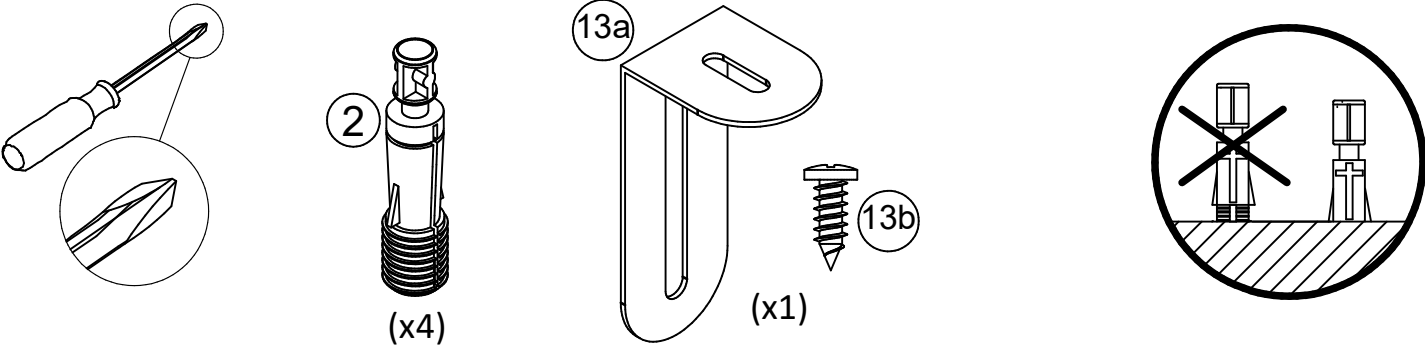

# Step 10

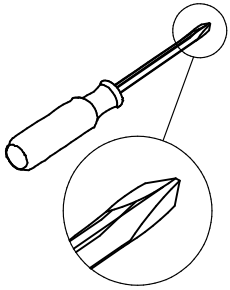

**finished edged face up**

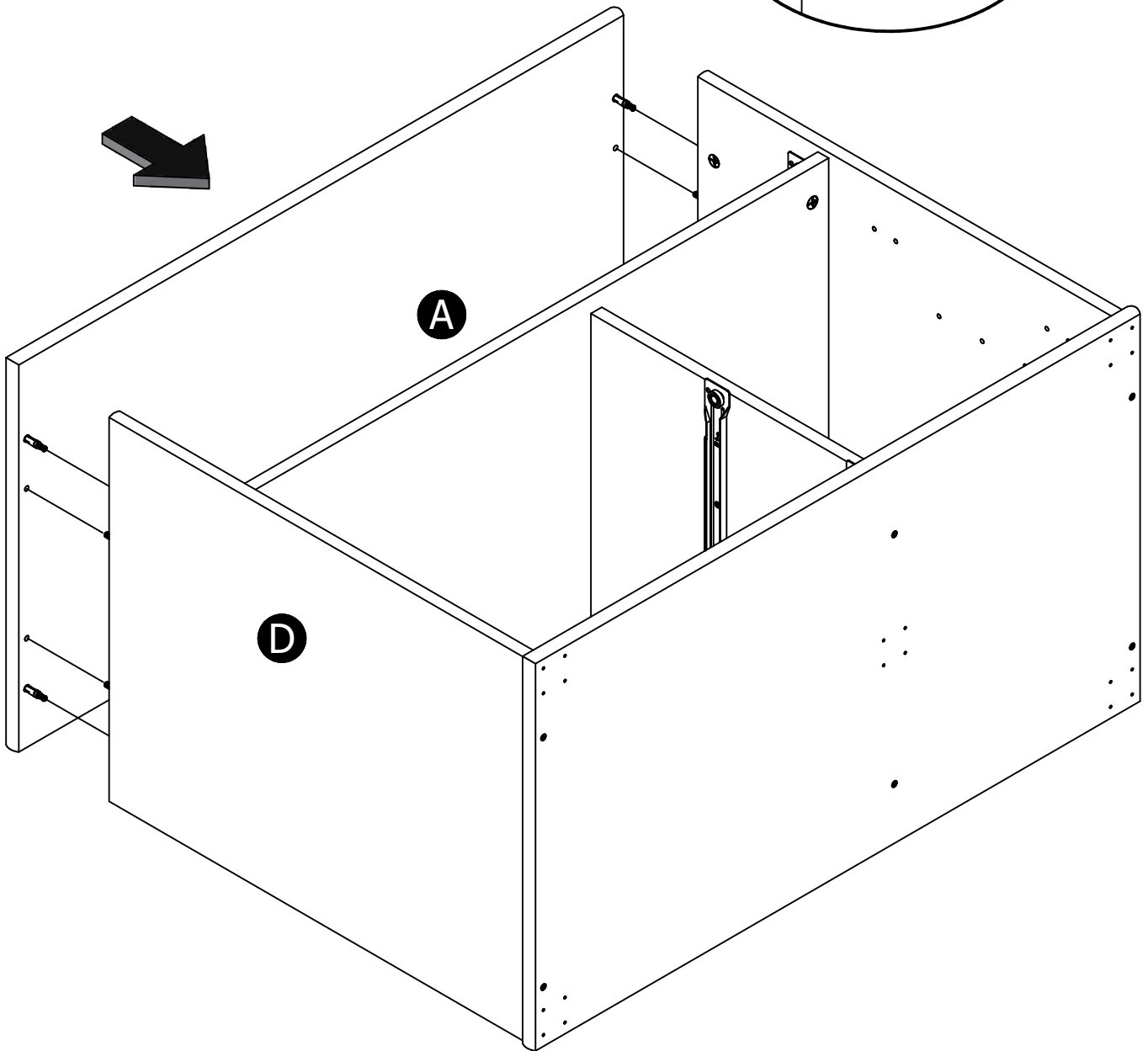
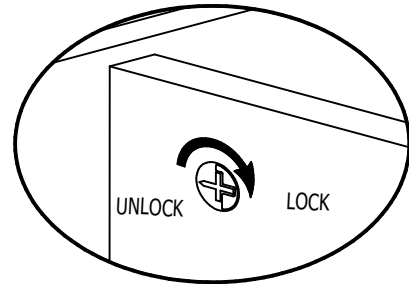

# Step 11

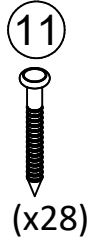

**IMPORTANT! THE BACK PANEL IS A STRUCTURAL PART OF THIS UNIT AND MUST BE INSTALLED PROPERLY.**

**2 people are required for this step.**  
Carefully turn the unit over onto its front as shown.

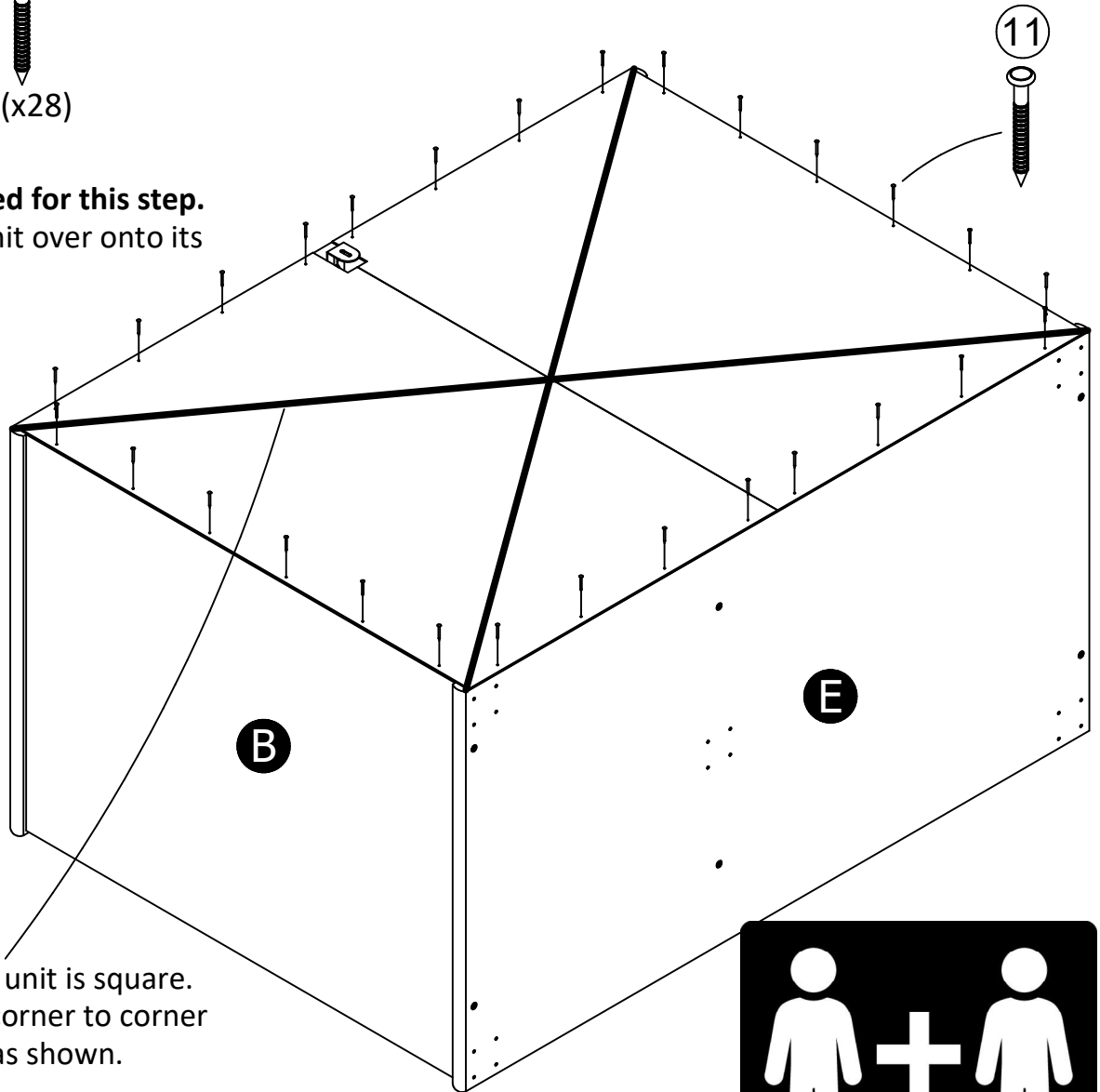

Assure that the unit is square.  
Distance from corner to corner  
must be equal as shown.

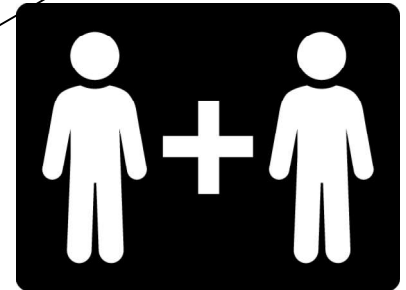

Align the bottom edge of the back panel with the lower edge of the bottom shelf (E). Align side edges with edge of left and right panels (A&B) and nail straight into back edges as shown.

# Step 12

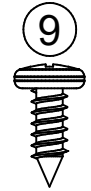
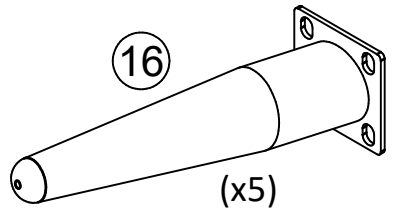
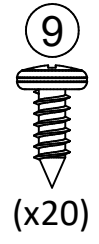
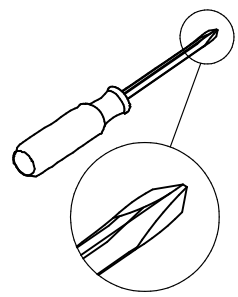

Do not get screw #8 and #9 mixed up. Screw #9 has a larger head and body.

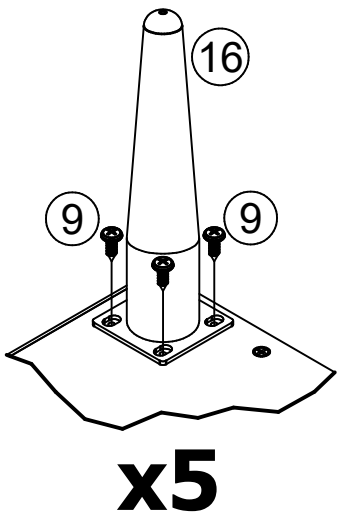
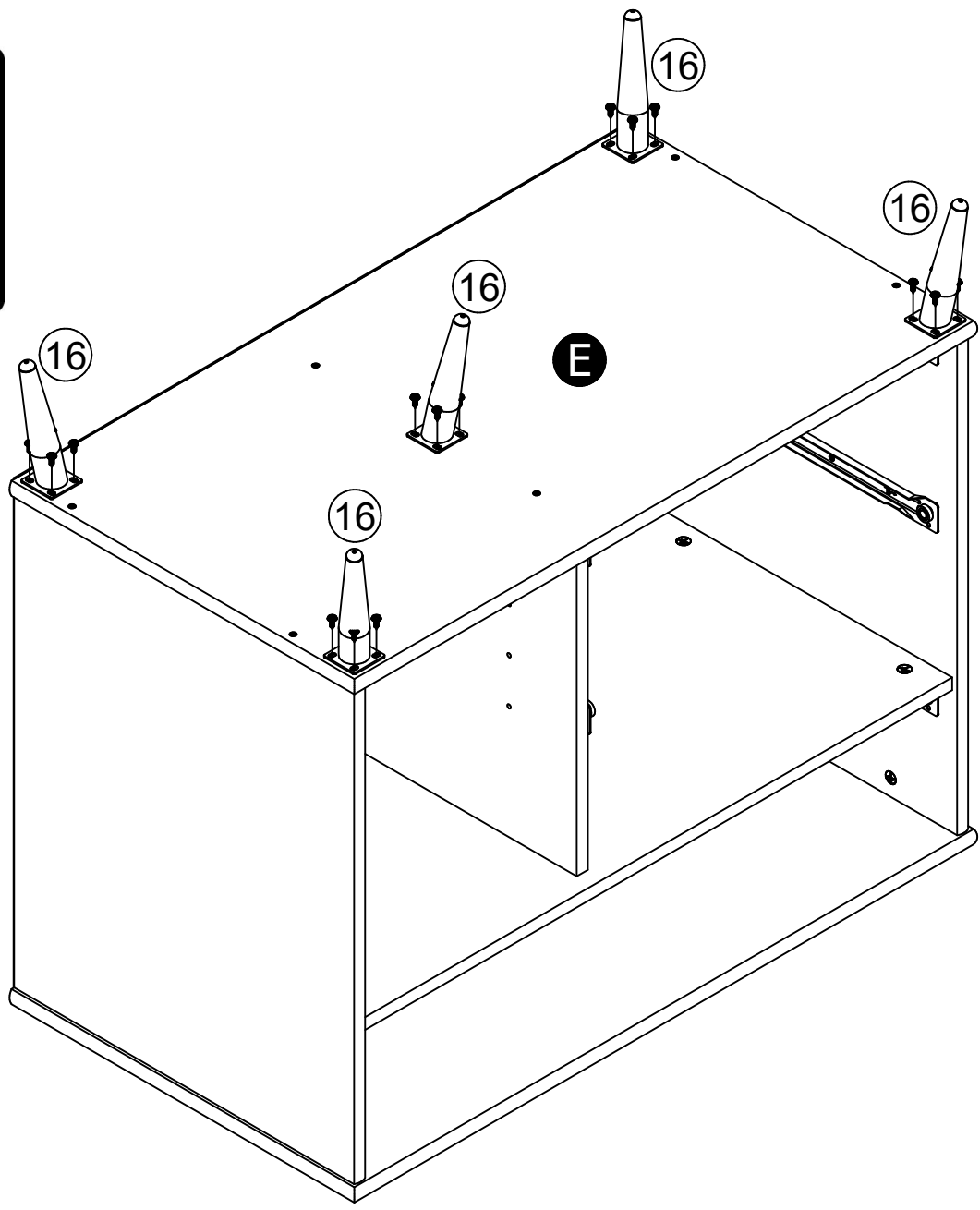
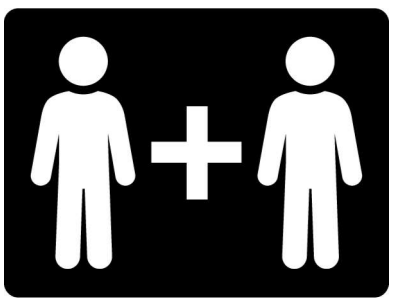

# Step 13

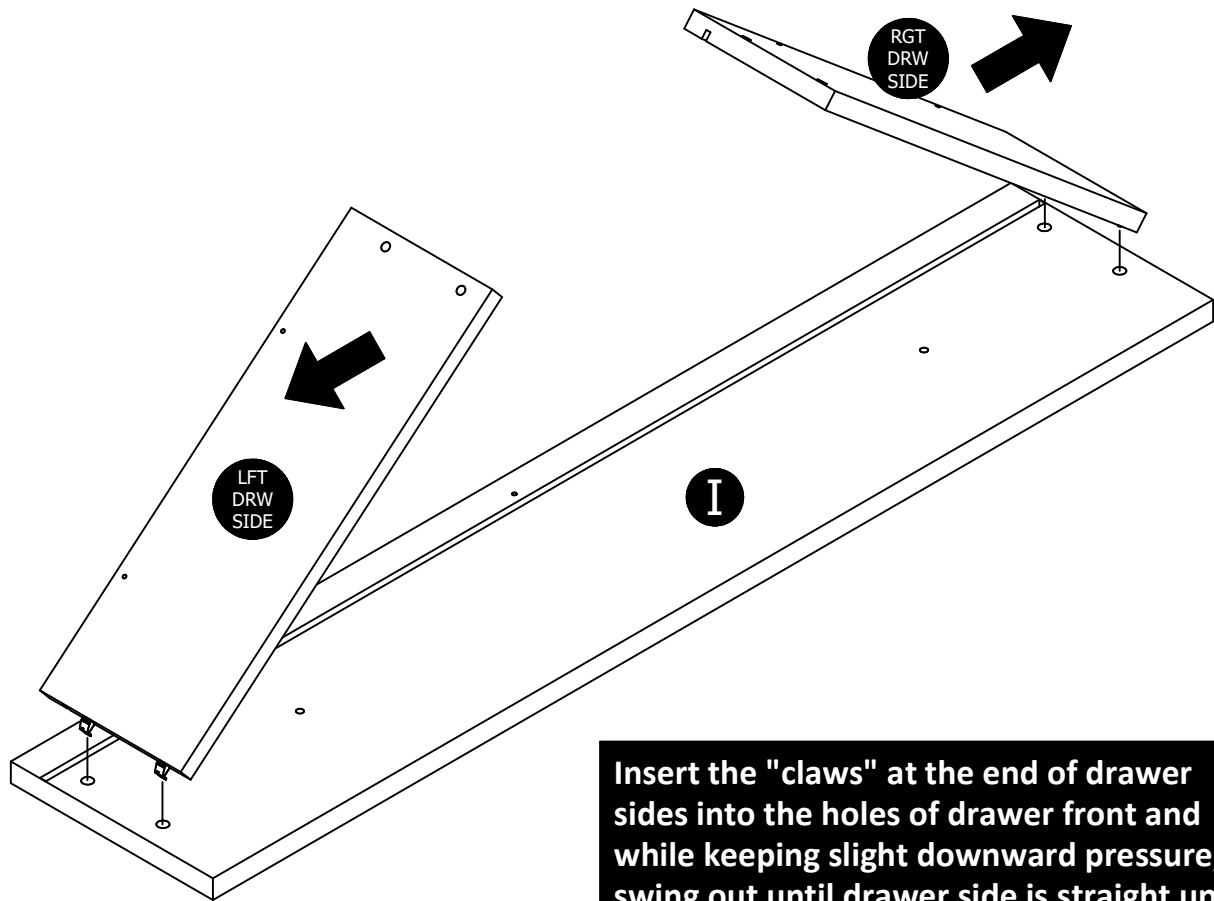

Insert the "claws" at the end of drawer sides into the holes of drawer front and while keeping slight downward pressure, swing out until drawer side is straight up. NOTE: The drawer sides will be slightly unstable until the drawer bottom is installed (step 14).

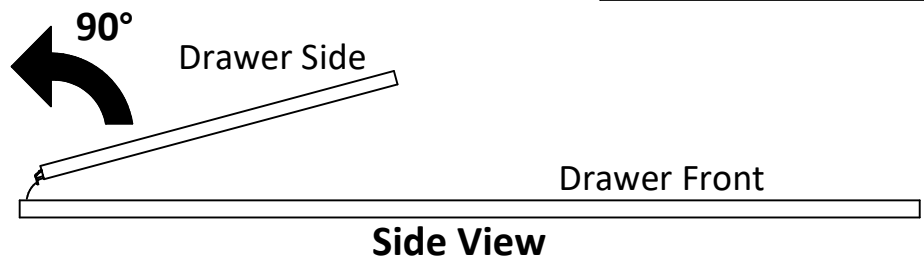

# Step 14

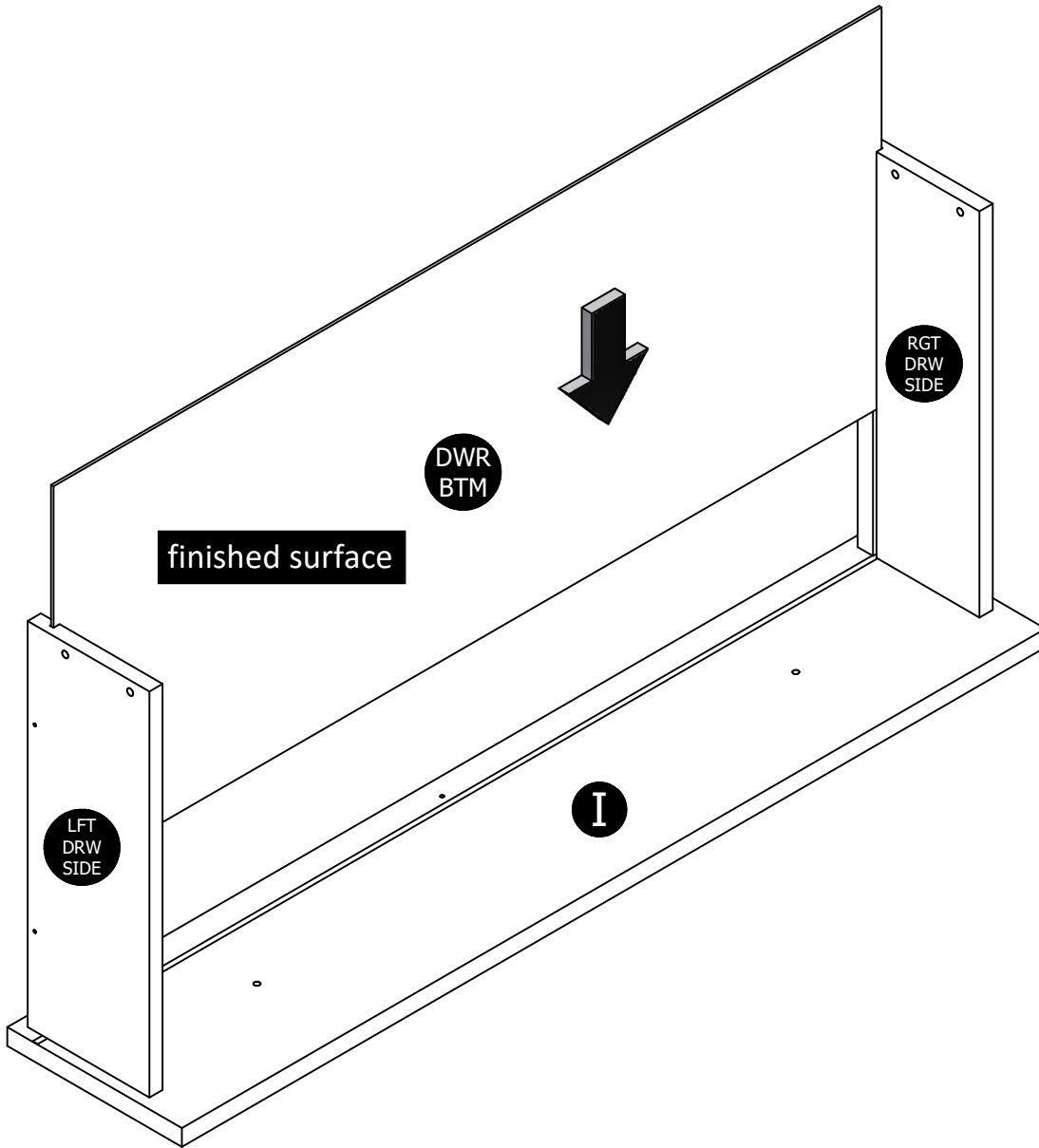



# Step 15



You will need to tap with a hammer to fasten.

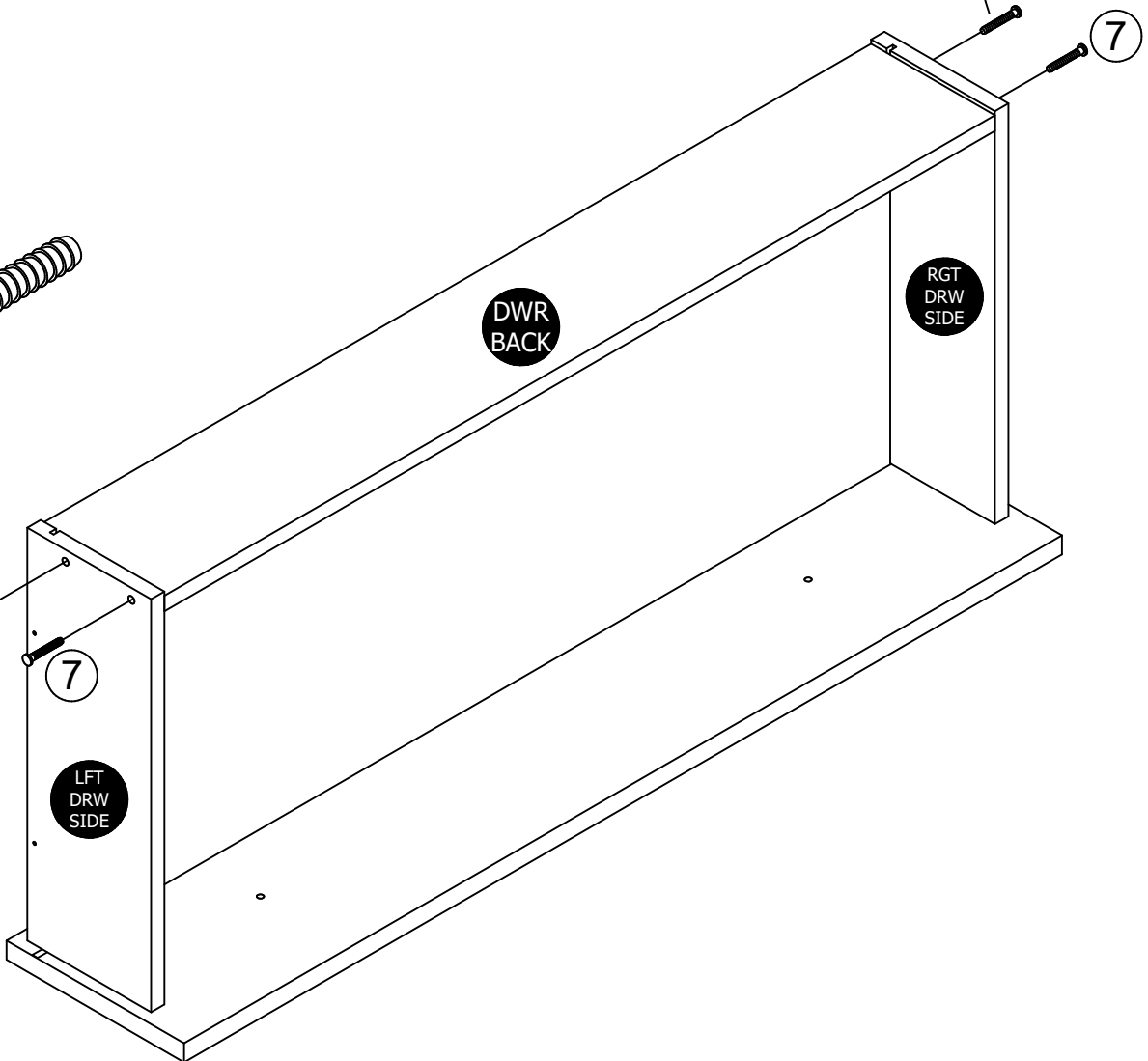
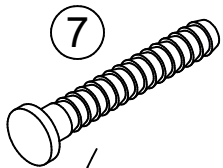
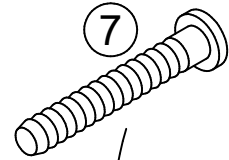

# Step 16

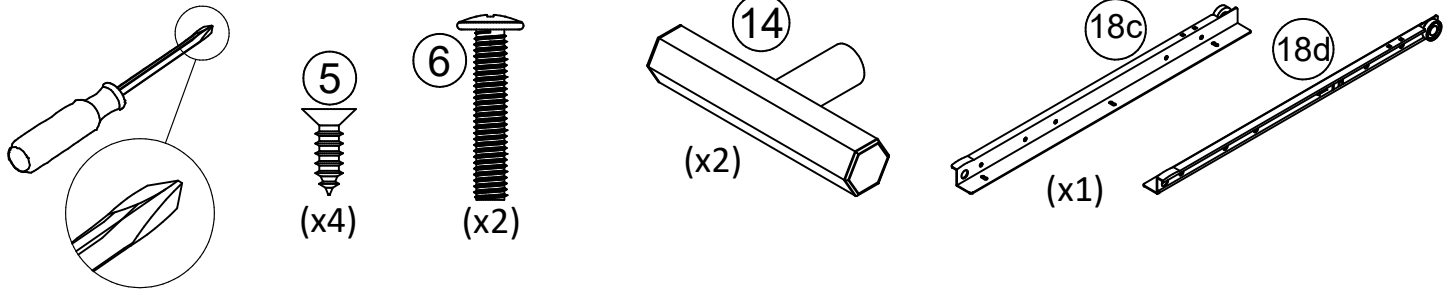

Attach the handles after the slides are mounted.

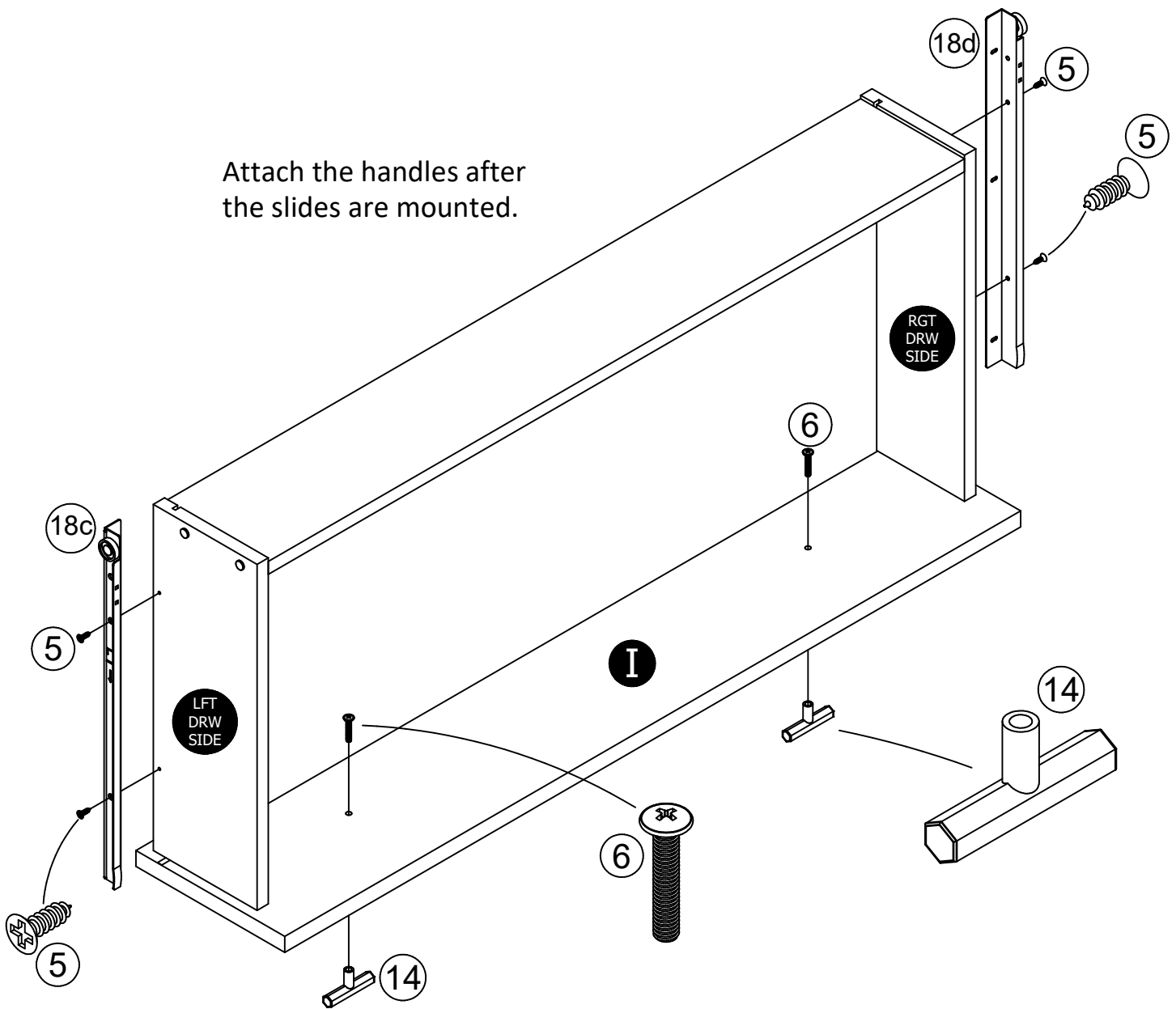

# Step 17

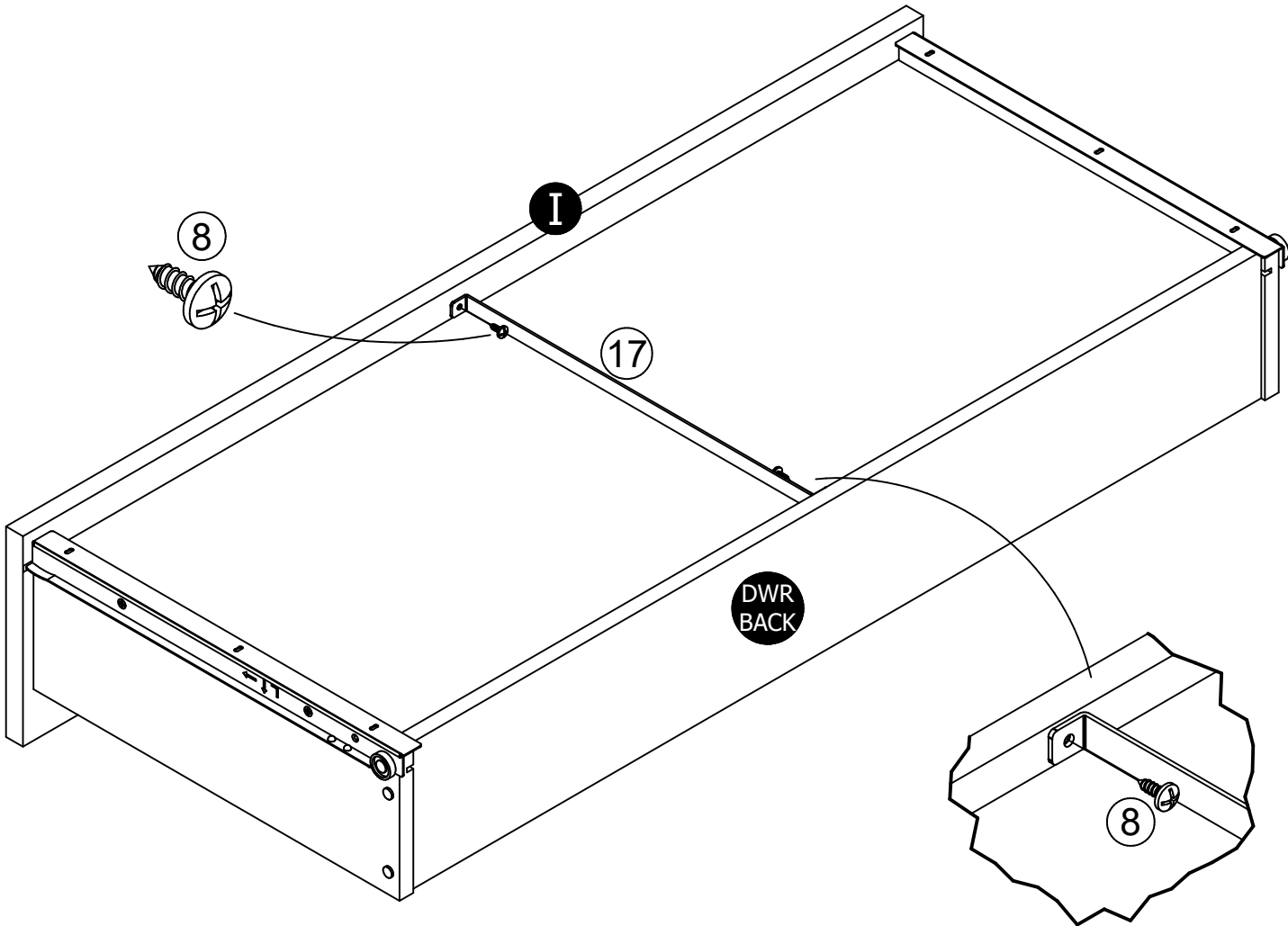
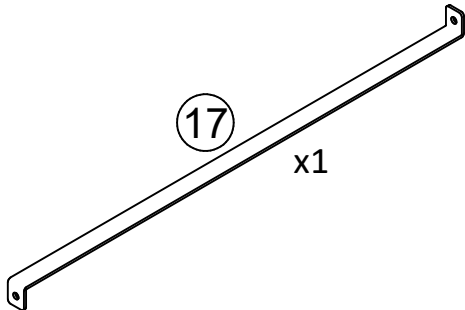
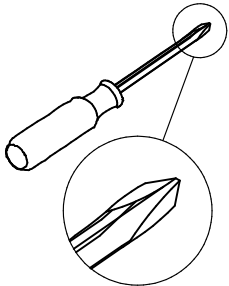

# Step 18

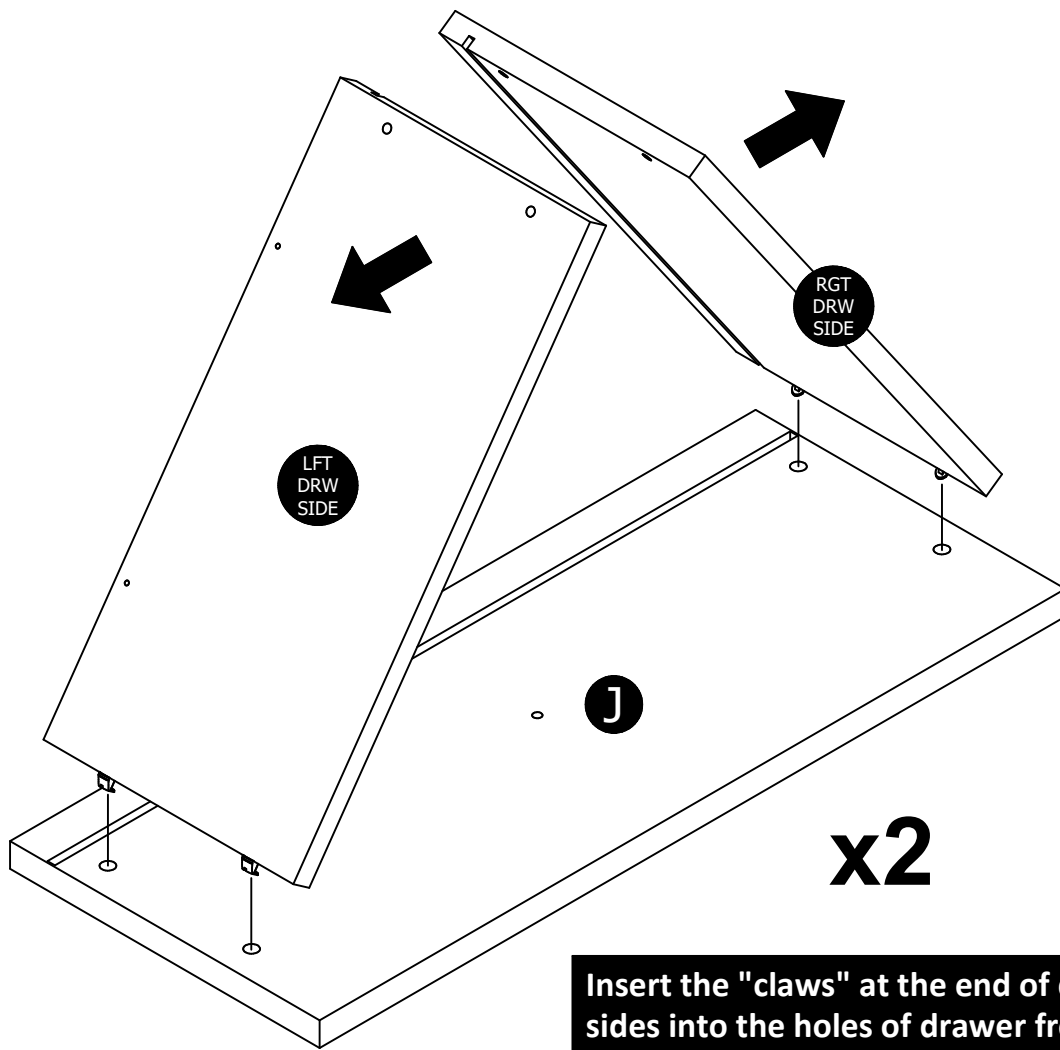

Insert the "claws" at the end of drawer sides into the holes of drawer front and while keeping slight downward pressure, swing out until drawer side is straight up. NOTE: The drawer sides will be slightly unstable until the drawer bottom is installed (step 19).

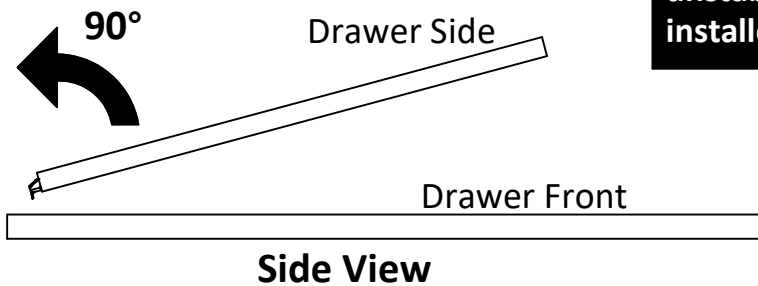

# Step 19

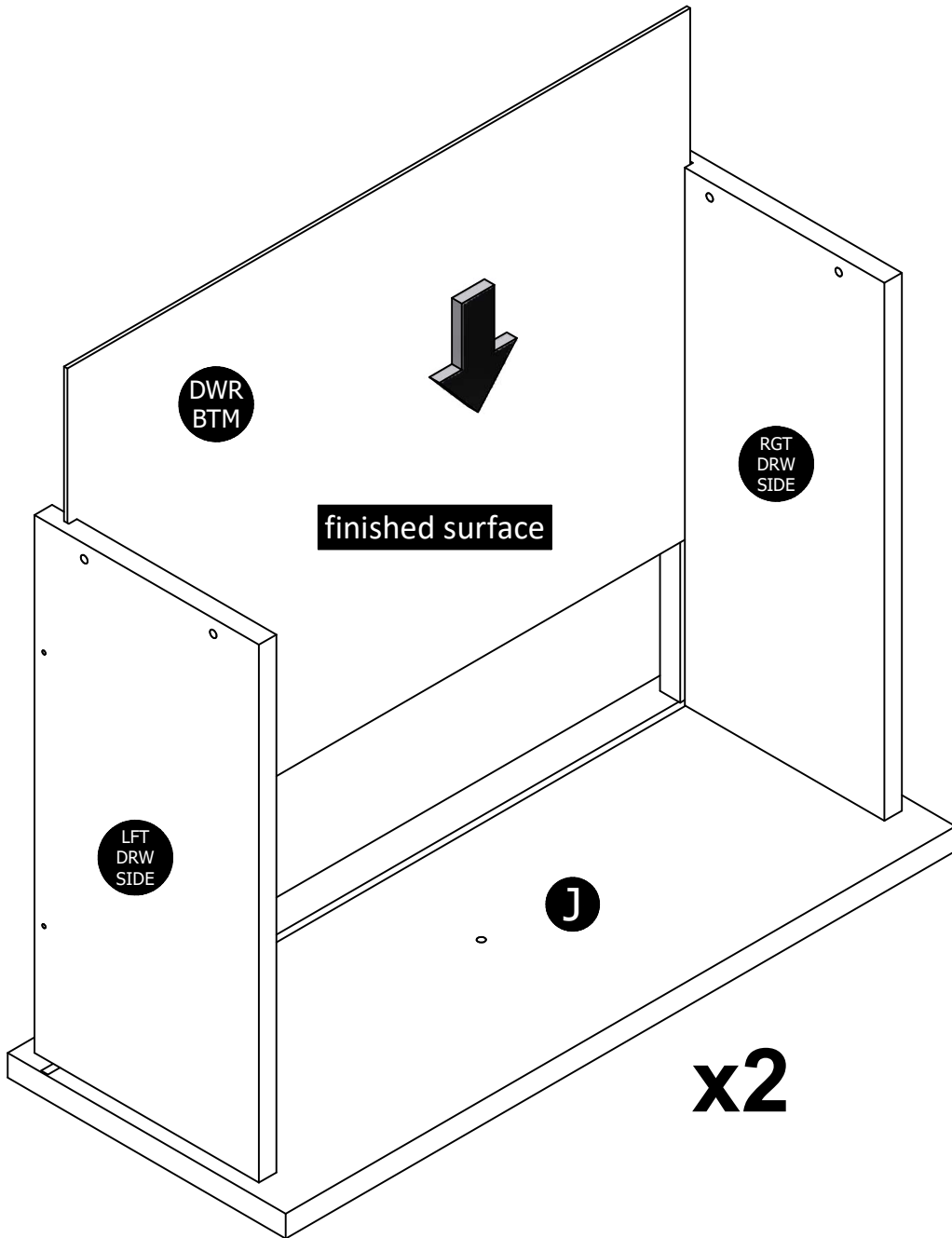

# Step 20



You will need to tap with a hammer to fasten.

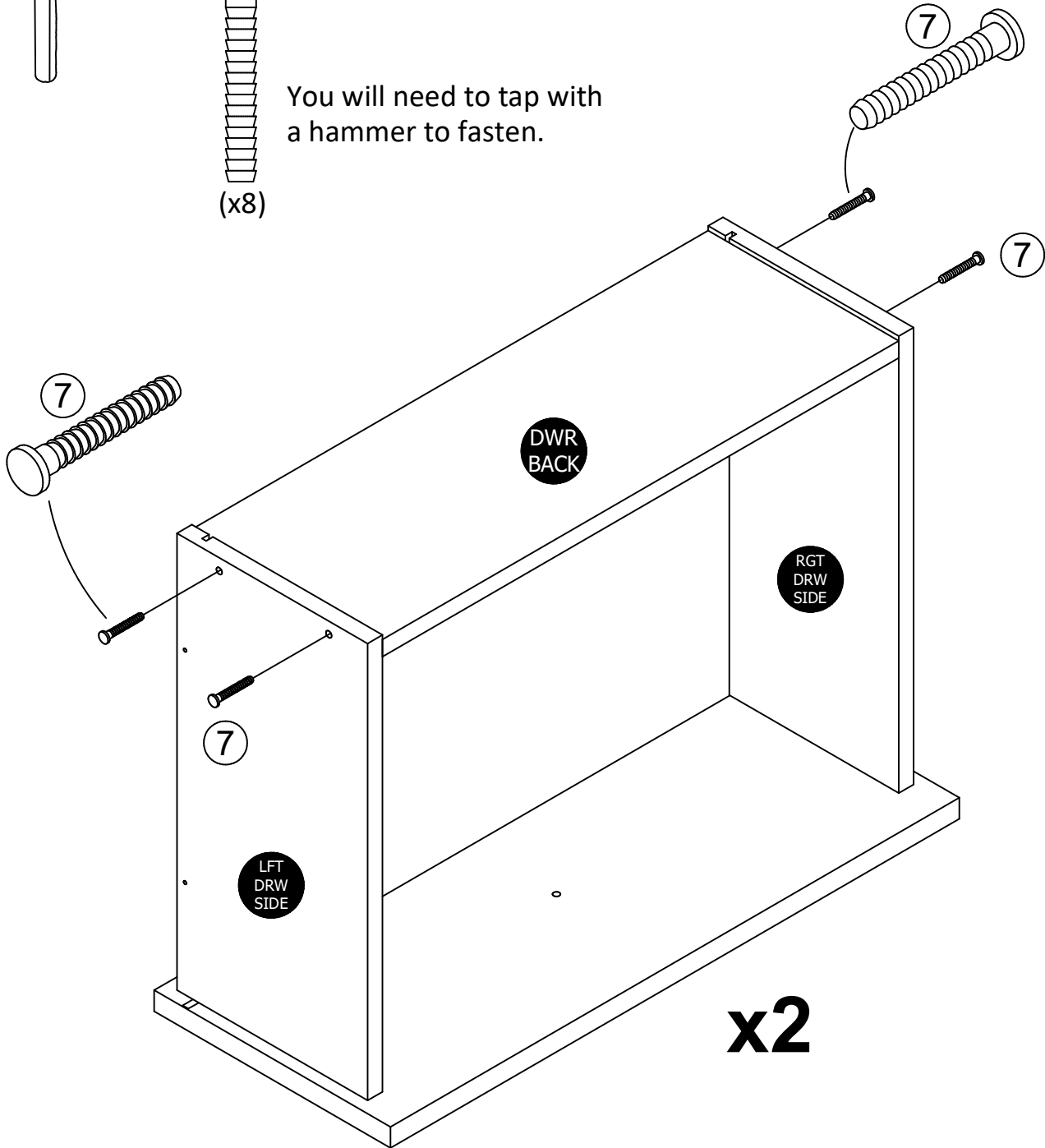

# Step 21

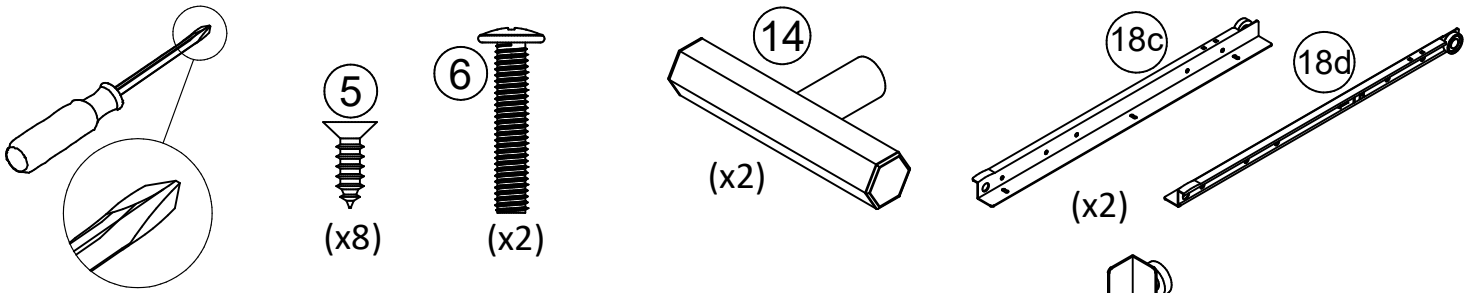

Attach the handles after the slides are mounted.

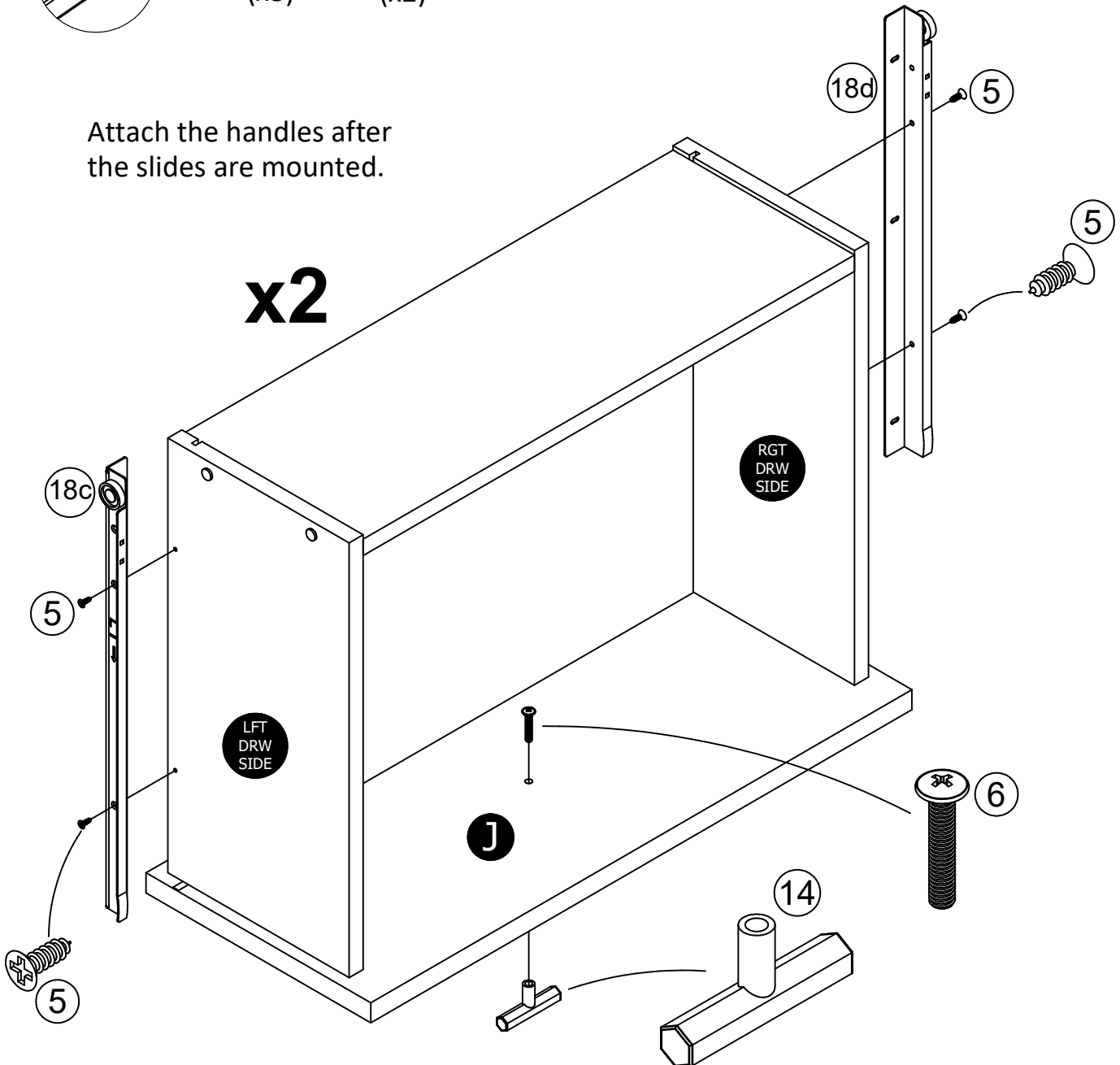

# Step 22

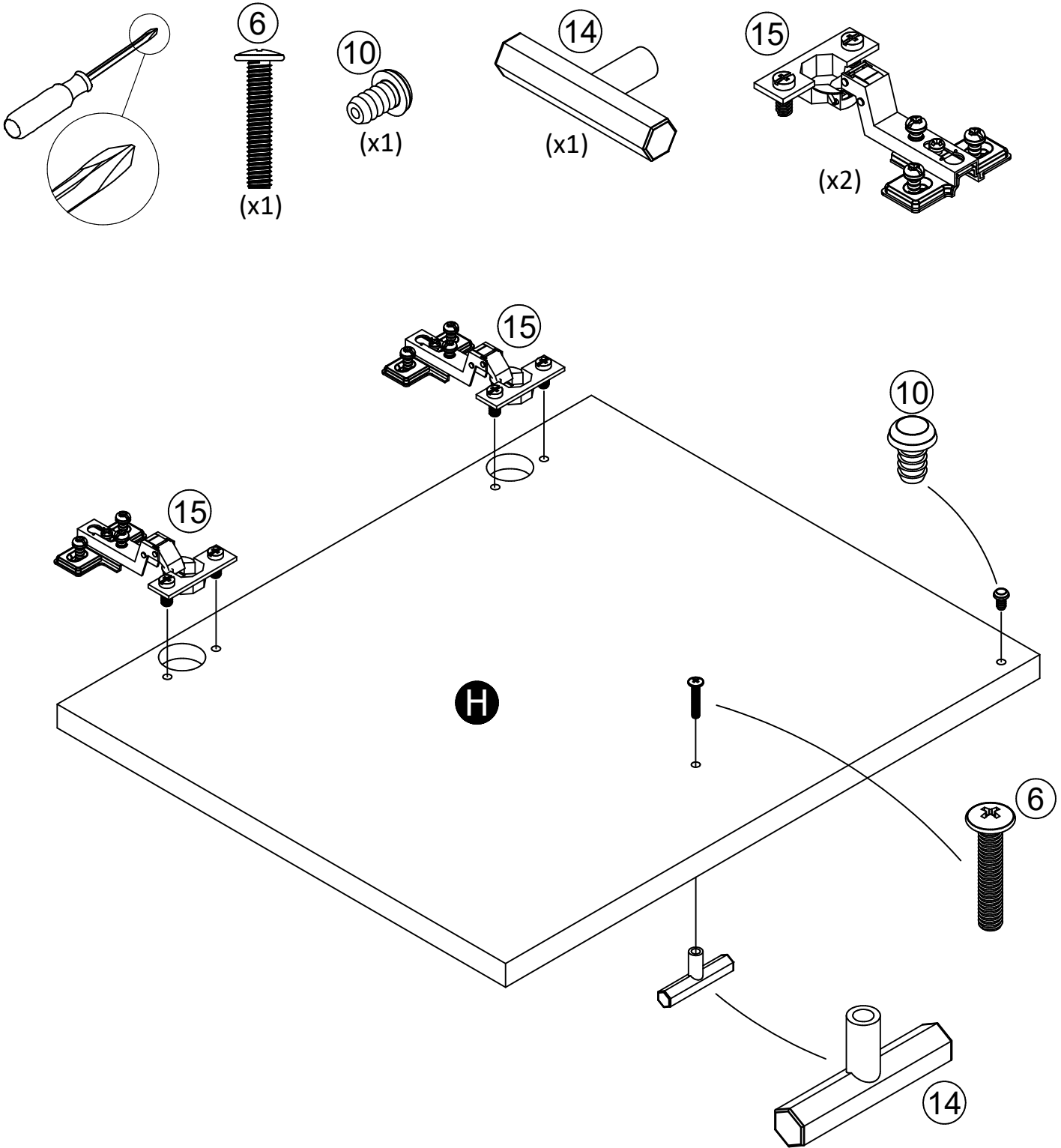



# Step 23

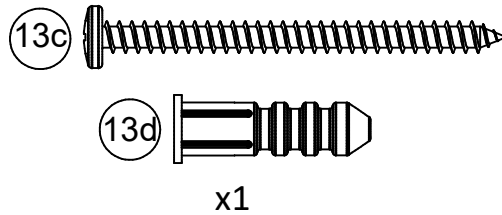
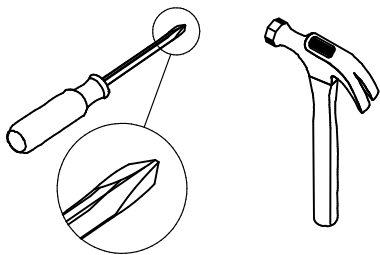

**For Masonry, Concrete, or other wall materials:**  
Consult your local hardware store for appropriate anchors to securely attach the safety bracket.

**IMPORTANT:** THIS UNIT MUST BE SECURE TO THE WALL TO HELP PREVENT TIPOVER. FOLLOW THESE INSTRUCTIONS TO INSTALL THE ANTI-TIPPING SAFETY BRACKET PROVIDED WITH THIS PRODUCT.

## WARNING

**Serious or fatal crushing injuries can occur from furniture tipover.**

### To prevent tipover:

- \* Install tipover restraint provided
- \* Place heaviest items in the lowest drawers
- \* Unless specifically designed to accommodate, do not set TVs or other heavy objects on the top of this product
- \* Never allow children to climb or hang on drawers, door, or shelves
- \* Never open more than one drawer at a time

**Use of tipover restraints may only reduce, but not eliminate the risk of tipover**

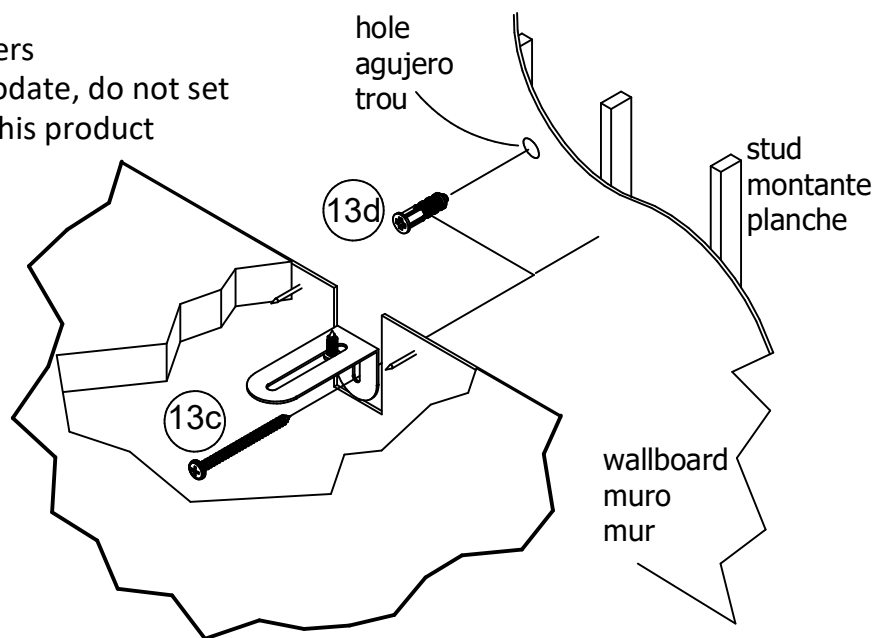

### OPTION 1: Attachment into a wall stud (preferred method)

Using a stud finder, locate a stud in the wall. Place your unit against the wall, with the safety bracket aligned in this location. To make driving the screw easier, you can drill a 1/8" diameter pilot hole (3mm) through the safety bracket into the stud. Drive the screw through the safety bracket into the wall stud. Tighten the screw that was not fully tightened in step 9.

### OPTION 2: Attachment into drywall

Locate your unit where desired against a wall and mark the wall through the safety bracket, then move your unit aside. Drill a 3/16" diameter hole (5mm) into the wallboard. Tap the wall anchor into the hole until it is flush. Move your unit into location and fasten the wall bracket to the wall anchor with the screw. Tighten the screw that was not fully tightened in step 9.

# Step 24

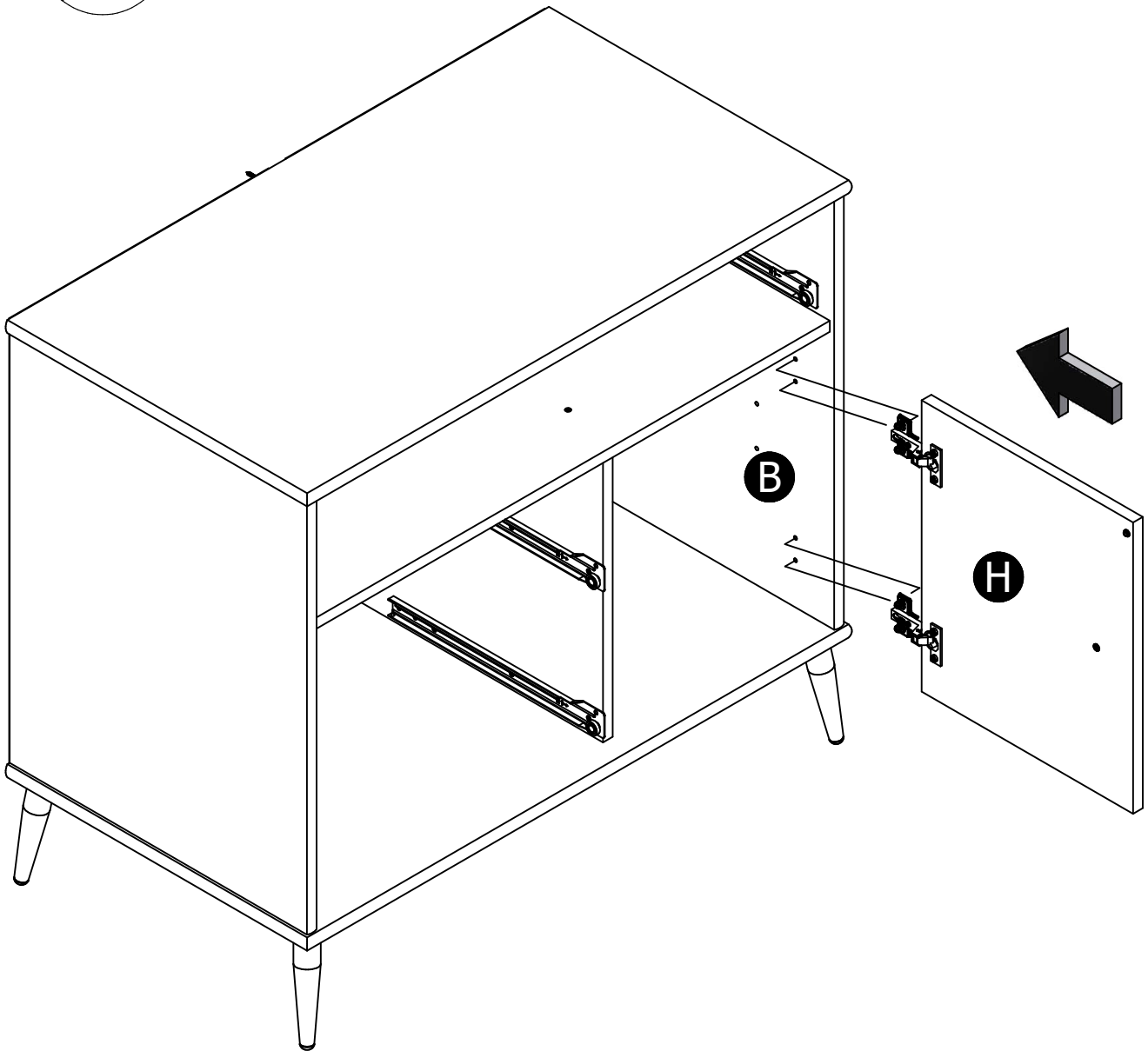
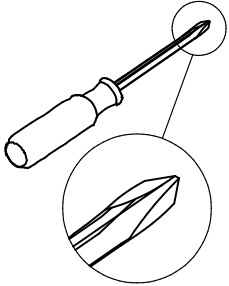

# Step 25

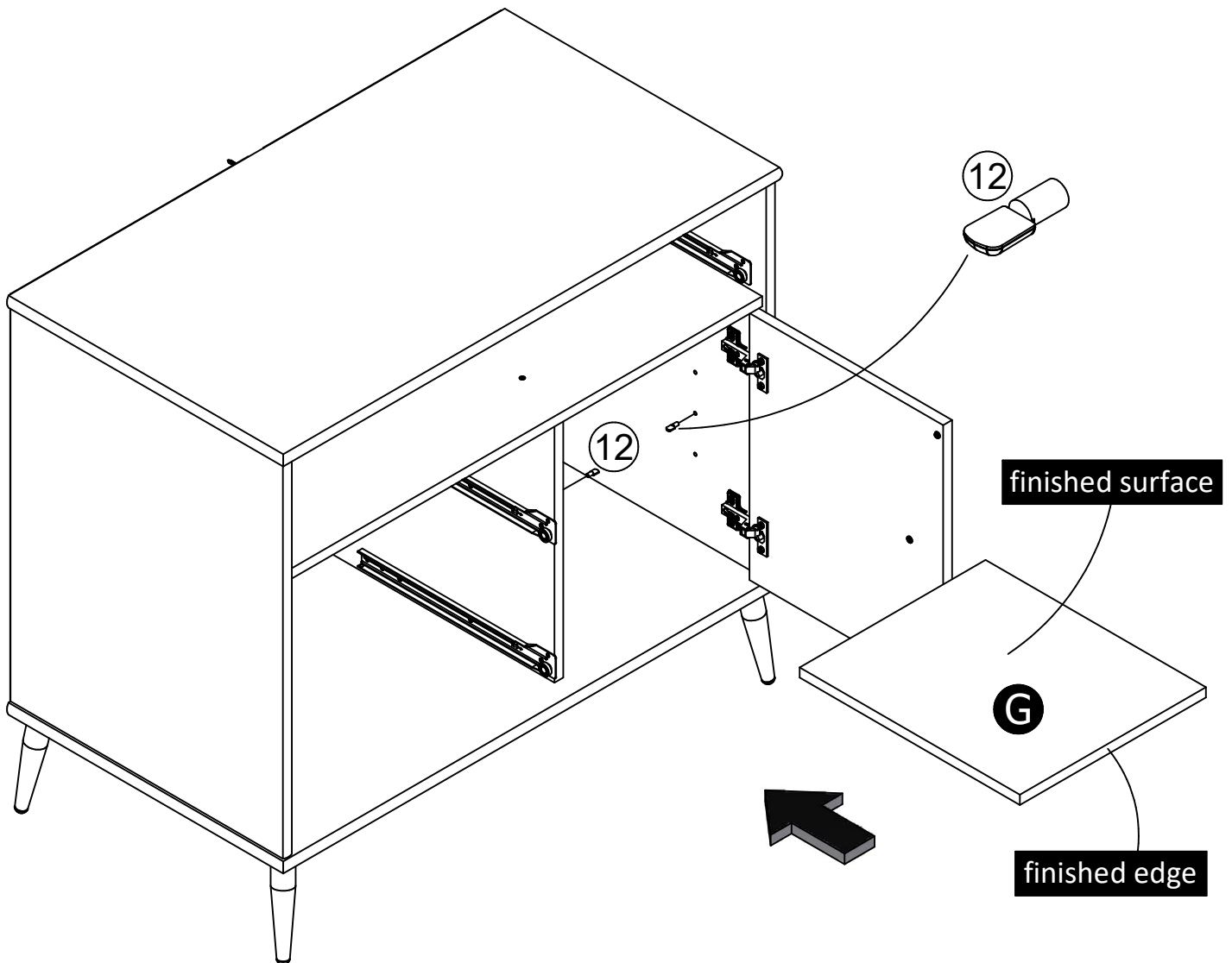
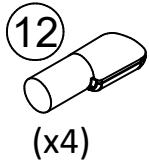

# Step 26

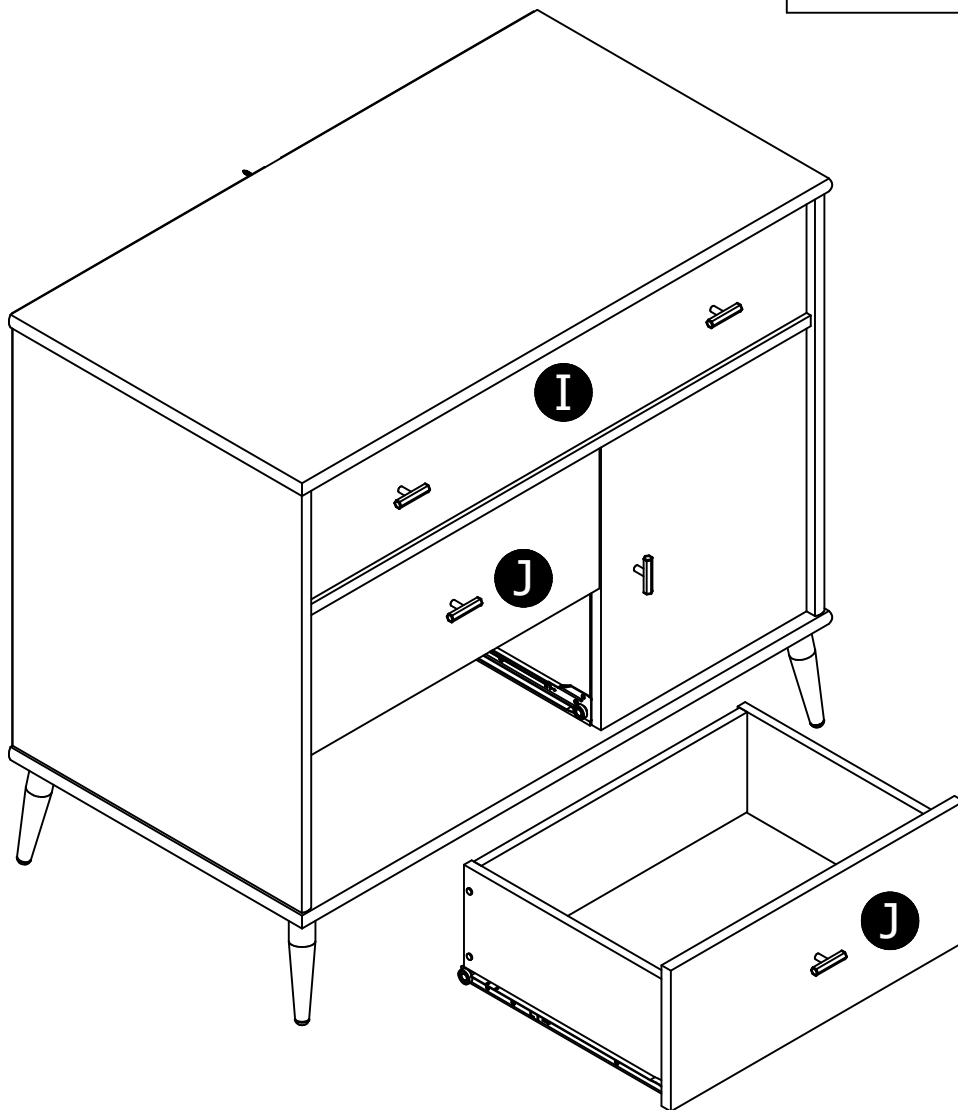
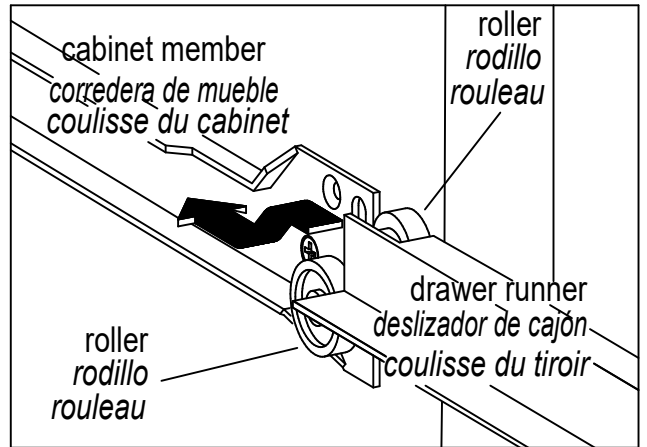

# Step 27

## Door Adjustment

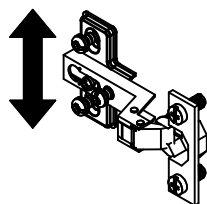
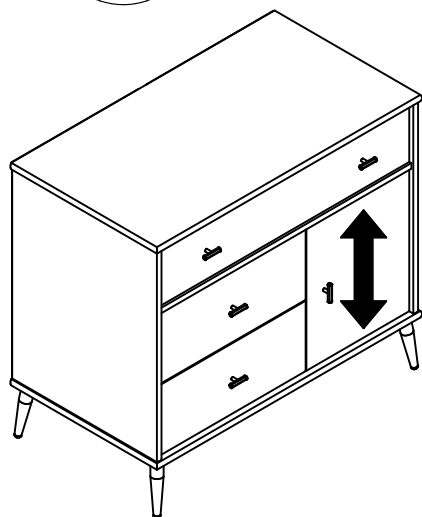
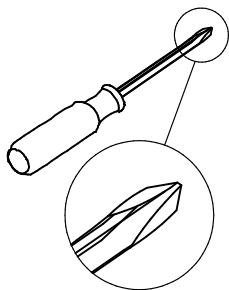

**To adjust the vertical height:**  
Loosen the screws "A" on both hinges. They are usually in slotted holes which allows you to adjust up or down by a few mm. Then tighten back up.

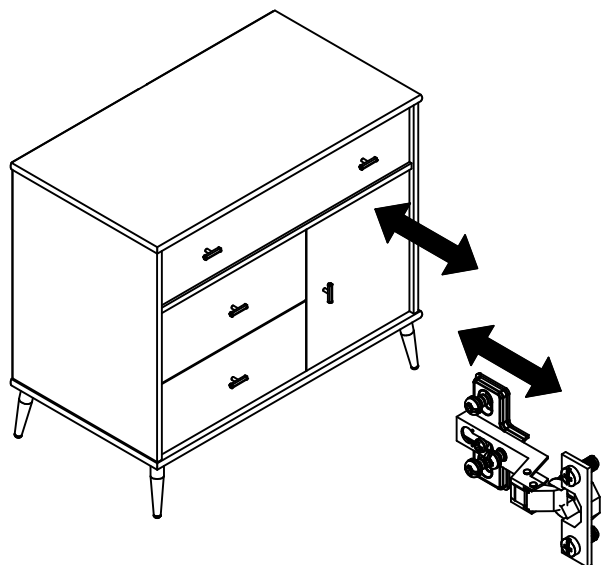
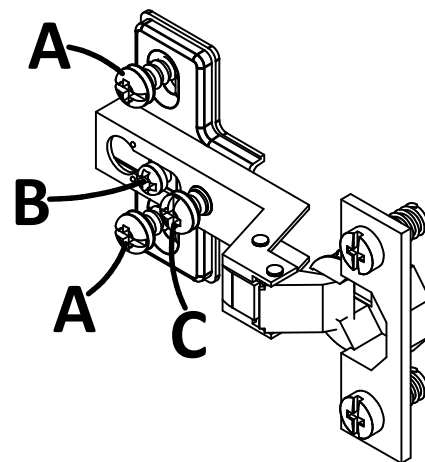

**To adjust the depth:**  
Loosen the screw "B" and adjust door.

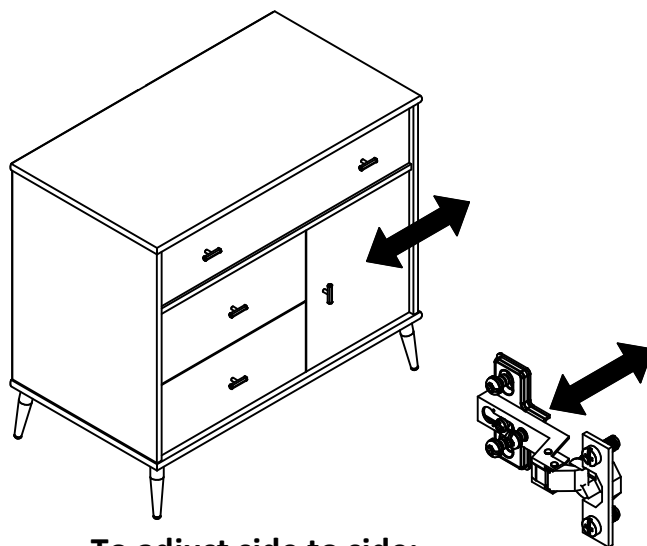

**To adjust side to side:**  
Loosen the screw "C" on BOTH hinges and tighten "B" moves door outward. Loosen "B" and tighten "C" moves doors inward.

This unit has been designed to support the maximum loads shown. Exceeding these load limits could cause sagging, instability, product collapse, and/or serious injury.

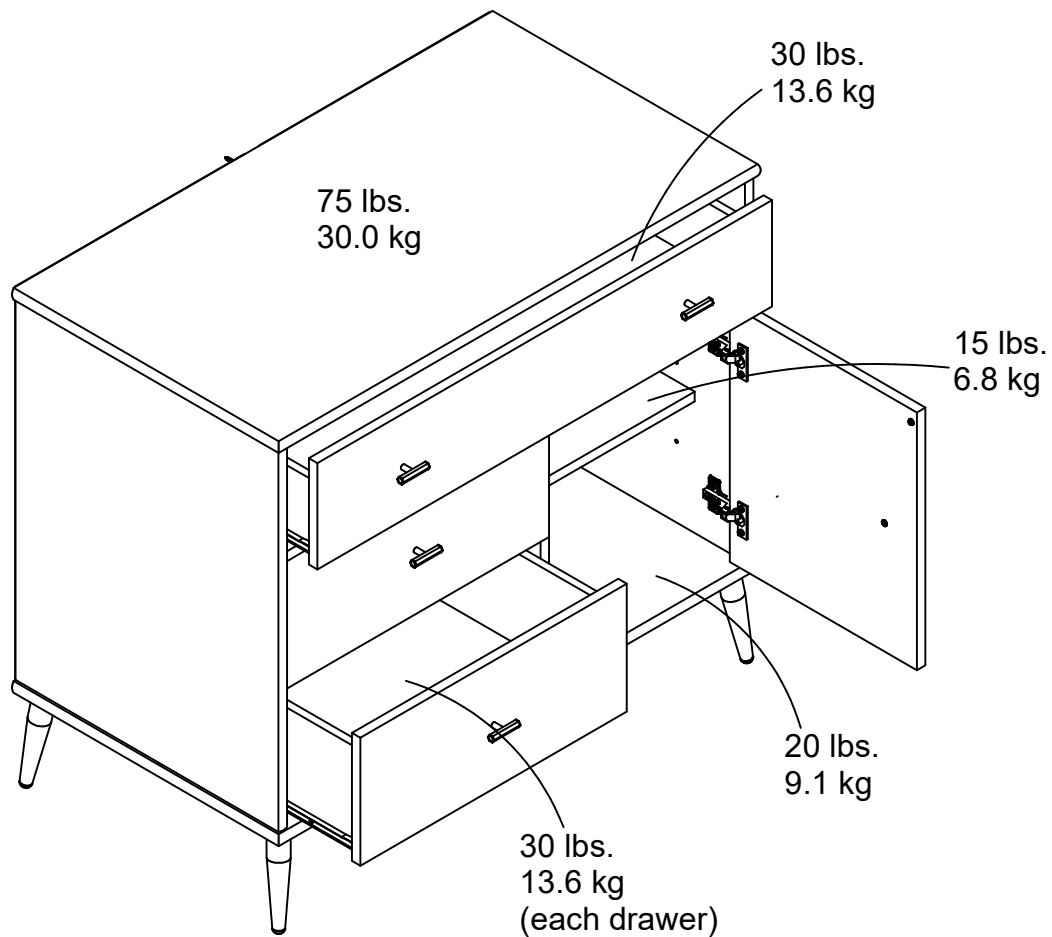

**Warning: Risk of injury to persons - do not place a television on this furniture. This furniture is not approved for use with a television.**

#### Certificate of Conformity

1. This certificate applies to the Dorel Home Furnishings, Inc. product identified by this instruction manual.
2. This certificate applies to compliance of this product with the CPSC Ban on Lead-Containing Paint (16 CFR 1303).
3. This product is distributed by: Dorel Home Furnishings, Inc.  
410 East First Street South  
Wright City, MO 63390  
636-745-3351
4. Site of Manufacture: Tiffin OH
5. See front page of instruction manual for date of manufacture.



---

## Register your product to receive the following:



- \* New trend details - sneak peek on what's new
- \* Surveys - have a voice within our community
- \* Exclusive deals and discount codes
- \* Quick and easy replacement part service

To register your product, visit [littleseedskids.com](http://littleseedskids.com)

## *5 Star Rating*



Visit your local retailer's website, rate your purchased product and leave us some feedback!

We would like to extend a big "Thank You" to all of our customers for taking the time to assemble this Little Seeds product, and to give us your valuable feedback.

*Thank You!*



---

## Consejos Útiles (página 3)

- Abra su artículo en el área donde usted planea utilizarlo para evitar levantar y moverlo menos pesado
- Identificar, ordenar y contar las piezas antes de intentar ensamblar
- Las clavijas de compresión se golpean con un martillo
- Las diapositivas están marcadas con una R (derecha) y L (izquierda) para la colocación correcta
- Asegúrese de que siempre el punto localizado en la parte superior de bloqueador de leva este volteado hacia borde exterior
- Utilizar todos los clavos para el panel de atrás y distribuirlos por igual
- El panel el atrás debe utilizarse para asegurarse de que la unidad queda fija y firme
- No use químicas fuertes ni limpiadores abrasivos en este artículo.
- Nunca empuje, tire ni arrastre los muebles

## Antes de Que Empieces (página 9)

- Lea cuidadosamente cada paso y siga el orden correcto
- Separar y contar todas sus piezas y hardware
- Dése suficiente espacio para el proceso de ensamble
- Tenga las siguientes herramientas: destornillador de cabeza plana, cabeza Phillips destornillador y martillo

## Sistema de fijar el bloqueo de leva: (página 9)

Este sistema de fijar el bloqueo de leva será usado en todo proceso ensamble.

### Paso 1

Precaución: Si utiliza un taladro eléctrico o un destornillador eléctrico para atornillar, por favor sea consciente de cuándo reducir la velocidad y de detenerse cuando el tornillo quede ajustado. En caso contrario, corre el riesgo de pasarse de rosca.

### Paso 9

No apretar este tornillo por completo en este paso.



## Paso 11

**¡IMPORTANTE! EL PANEL TRASERO CONSTITUYE UNA PARTE ESTRUCTURAL DE ESTA UNIDAD Y DEBE INSTALARSE CORRECTAMENTE.**

**Se necesitan 2 personas para este paso.**

Voltear la unidad cuidadosamente y colocarla sobre su frente como se muestra.

Asegurarse de que la unidad esté en escuadra.

La distancia de una esquina a la otra debe ser la misma, como se muestra aquí.

Alinear el borde inferior del panel trasero con el borde inferior del estante del fondo (E). Alinear los bordes laterales con el borde de los paneles izquierdo y derecho (A&B) y clavar directamente en los bordes traseros como se muestra.

## Paso 12

No confundir los tornillos #8 y #9.

El tornillo #9 tiene la cabeza y el cuerpo más grandes.

## Paso 13

Inserte los "ganchos" al final de los laterales de la gaveta dentro de los agujeros del frente de la misma y, manteniendo una leve presión hacia abajo, balancee hacia afuera hasta que el lateral de la gaveta quede recto.

NOTA: Los lados del cajón estarán ligeramente inestables hasta que el fondo del cajón esté instalado (paso 14).

## Paso 15

Tendrá que martillar un poco para que queden bien colocados.

## Paso 16

Colocar los tiradores después de haber montado las guías.

## Paso 18

Inserte los "ganchos" al final de los laterales de la gaveta dentro de los agujeros del frente de la misma y, manteniendo una leve presión hacia abajo, balancee hacia afuera hasta que el lateral de la gaveta quede recto.

NOTA: Los lados del cajón estarán ligeramente inestables hasta que el fondo del cajón esté instalado (paso 19).

## Paso 20

Tendrá que martillar un poco para que queden bien colocados.

## Paso 21

Colocar los tiradores después de haber montado las guías.

## Paso 23

**En el caso de mampostería, concreto u otros materiales de pared:**

Consulte en su ferretería local para que le proporcionen los elementos apropiados para asegurar el soporte de seguridad.

**IMPORTANTE:** ESTA UNIDAD DEBE AFIRMARSE A LA PARED PARA EVITAR QUE SE VUELQUE. SIGA ESTAS INSTRUCCIONES PARA INSTALAR EL SOPORTE DE SEGURIDAD CONTRA VUELCOS QUE VIENE CON ESTE PRODUCTO.

### ADVERTENCIA

**El vuelco de muebles puede provocar heridas graves o fatales.**

**Para prevenir un vuelco:**

- \* Instalar la sujeción contra vuelcos
- \* Colocar los objetos más pesados en los cajones que se encuentran más abajo
- \* A menos que esté específicamente diseñado para acomodarlo, no coloque televisores u otros objetos pesados en la parte superior de este producto
- \* Jamás le permita a los niños que trepen o se cuelguen de la puerta, los cajones o los estantes
- \* Nunca abra más de un cajón a la vez

**El uso de las sujeciones contra vuelcos puede reducir, pero no eliminar el riesgo de vuelcos**

### OPCIÓN 1: Montaje en un tarugo o taquete en la pared (método predilecto)

Utilizando un detector de clavos, ubique un remache en la pared. Coloque su unidad contra la pared con el soporte de seguridad alineado en este lugar. Para introducir el tornillo más fácilmente, puede hacer un orificio guía de 1/8" (3 mm) de diámetro a través del soporte de seguridad y en el remache. Introduzca el tornillo a través del soporte de seguridad en el tarugo o taquete en la pared. Ajuste el tornillo que no había quedado completamente ajustado en el paso 9.

## **OPCIÓN 2: Montaje en una placa de yeso**

Coloque su unidad donde lo desee contra la pared y marque la pared a través del soporte de seguridad, luego corra la unidad a un costado. Taladre un agujero de 3/16" (5 mm) de diámetro en la placa de la pared. Martille la grampa o anclaje en el agujero hasta que quede nivelado. Mueva la unidad hacia el lugar y ajuste el soporte de pared a la grampa con el tornillo. Ajuste el tornillo que no había quedado completamente ajustado en el paso 9.

## **Paso 27**

Ajustar la puerta

### **Para ajustar la altura vertical:**

Aflojar los tornillos "A" de ambas bisagras. Normalmente están en ranuras, lo que permite ajustar unos milímetros hacia arriba o hacia abajo. Luego, volver a ajustarlos.

### **Para ajustar la profundidad:**

Aflojar el tornillo "B" y ajustar la puerta.

### **Para ajustar los laterales:**

Aflojar el tornillo "C" de AMBAS bisagras y, al ajustar "B", se desplaza la puerta hacia afuera. Aflojar "B" y ajustar "C" mete la puerta hacia adentro.

## **Página 38**

### **CHARGES MAXIMALES**

Ce meuble a été conçu pour supporter les charges maximales indiquées. En excédant ces limites de charge, le meuble pourrait devenir instable, s'effondrer, et/ou causer des blessures graves.

AVERTISSEMENT : Risque de blessure corporelle - ne pas placer une télévision sur ce meuble. Ce meuble n'est pas approuvé pour une utilisation avec une télévision.

## **Página 39**

Registre su producto para recibir lo siguiente:

- \* Detalles de nuevas tendencias - Vistazo a lo nuevo
- \* Encuestas - alec su voz entre su comunidad
- \* Códigos de ofertas y descuentos exclusivos
- \* Fácil y rápido servicio de partes de remplace

Para registrar su producto, visite [ameriwoodhome.com](http://ameriwoodhome.com)

Clasificación de 5 estrellas

Visite el sitio web de su tienda local, califique su comprado y denos sus comentarios!

Nos gustaría enviar un gran "Agradecimiento" a todos nuestros clientes por tomarse el tiempo de ensamblar este producto de Ameriwood Home, y por darnos sus valiosos comentarios.

Gracias

[littleseedskids.com](http://littleseedskids.com)

---

## Astuces Utiles

- Ouvrez votre article dans la zone que vous prévoyez de le garder pour moins de levage lourd
- Identifier, trier et compter les pièces avant d'essayer d'assembler
- Les goujons de compression sont taraudés avec un Marteau
- Les glissières sont marquées d'un R (droit) et d'un L (gauche) pour un bon placement
- Assurez-vous toujours de faire face la pointe situé sur le haut de la Serrure de Came vers le bord extérieur
- Utiliser tous les clous fournis pour le panneau arrière et les répartir également
- Le panneau arrière doit être utilisé pour vous assurer que votre appareil est robuste
- N'utilisez pas de produits chimiques agressifs ou de nettoyeurs abrasifs sur cet appareil
- Ne jamais pousser, tirer, ou faire glisser votre meuble

## Avant de Commencer

- Lisez attentivement chaque étape et suivez le bon ordre
- Séparez et comptez toutes vos pièces et matériaux
- Donnez-vous suffisamment de place pour l'assemblage
- Avoir les outils suivants: tournevis à tête plate, tournevis Phillips, et Marteau

## Système de Fixation de Came

Ce Système de Fixation de Came sera utilisé tout au long de l'assemblage

## Étape 1

Attention : Si vous utilisez une perceuse ou une visseuse électrique pour visser, veillez à ralentir et à vous arrêter lorsque la vis est serrée. Le non-respect de cette consigne peut entraîner la détérioration de la vis.

## Étape 9

Ne serrez pas complètement cette vis au cours de cette étape.

## Étape 11

**IMPORTANT! LE PANNEAU ARRIÈRE EST UNE PARTIE STRUCTURELLE DE CET APPAREIL ET DOIT ÊTRE INSTALLÉ CORRECTEMENT.**

**Deux personnes sont nécessaires pour cette étape.**

Retournez délicatement l'appareil sur sa face avant, comme indiqué.

Assurez-vous que l'unité est carrée.

La distance d'un coin à l'autre doit être égale, comme illustré.

Alignez le bord inférieur du panneau arrière avec le bord inférieur de la tablette inférieure (E).

Alignez les bords latéraux avec les bords des panneaux gauche et droit (A et B) et fixez-les directement sur les bords arrière, comme illustré.

## Étape 12

Ne confondez pas les vis n° 8 et n° 9.

La vis n° 9 a une tête et un corps plus grands.

## Étape 13

Insérez les « griffes » à l'extrémité des côtés du tiroir dans les trous de la façade du tiroir et, tout en maintenant une légère pression vers le bas, faites-les pivoter jusqu'à ce que le côté du tiroir soit droit.

REMARQUE : Les côtés du tiroir seront légèrement instables jusqu'à ce que le fond du tiroir soit installé (étape 14).

## Étape 15

Vous devrez taper avec un marteau pour fixer.

## Étape 16

Fixez les poignées après le montage des glissières.

## Étape 18

Insérez les « griffes » à l'extrémité des côtés du tiroir dans les trous de la façade du tiroir et, tout en maintenant une légère pression vers le bas, faites-les pivoter jusqu'à ce que le côté du tiroir soit droit.

REMARQUE : Les côtés du tiroir seront légèrement instables jusqu'à ce que le fond du tiroir soit installé (étape 19).

---

## Étape 20

Vous devrez taper avec un marteau pour fixer.

## Étape 21

Fixez les poignées après le montage des glissières.

## Étape 23

**Pour la maçonnerie, le béton ou d'autres matériaux muraux :**

Consultez votre quincaillerie locale pour obtenir des ancrages appropriés afin de fixer solidement le support de sécurité.

**IMPORTANT** : CET APPAREIL DOIT ÊTRE FIXÉ AU MUR POUR ÉVITER TOUT BASCULEMENT. SUIVEZ CES INSTRUCTIONS POUR INSTALLER LE SUPPORT DE SÉCURITÉ ANTI-BASCULEMENT FOURNI AVEC CE PRODUIT.

### AVERTISSEMENT

**Le basculement d'un meuble peut entraîner des blessures graves ou mortelles par écrasement.**

**Pour éviter le basculement :**

- \* Installer le dispositif de retenue en cas de basculement fourni
- \* Placez les articles les plus lourds dans les tiroirs les plus bas.
- \* À moins qu'il ne soit spécifiquement conçu pour s'y adapter, n'installez pas téléviseurs ou autres objets lourds sur le dessus de ce produit.
- \* Ne permettez jamais aux enfants de grimper ou de s'accrocher aux tiroirs, aux portes ou aux étagères.
- \* N'ouvrez jamais plus d'un tiroir à la fois.

**L'utilisation de dispositifs de retenue en cas de basculement ne peut que réduire, mais pas éliminer, le risque de basculement.**

### OPTION 1 : Fixation dans un montant de mur (méthode préférée)

À l'aide d'un détecteur de montants, localisez un montant dans le mur. Placez votre appareil contre le mur, avec le support de sécurité aligné à cet endroit. Pour faciliter l'introduction de la vis, vous pouvez percer un trou pilote de 3 mm de diamètre à travers le support de sécurité dans le montant. Enfoncez la vis à travers le support de sécurité dans le montant du mur. Serrez la vis qui n'a pas été entièrement serrée à l'étape 9.

---

### **OPTION 2 : Fixation dans le mur sec**

Placez votre appareil à l'endroit souhaité contre un mur et marquez le mur à travers le support de sécurité, puis mettez votre appareil de côté. Percez un trou de 3/16 pouces de diamètre (5 mm) dans le panneau mural. Tapez sur l'ancrage mural dans le trou jusqu'à ce qu'il soit affleurant. Mettez votre appareil en place et fixez le support mural à l'ancrage mural à l'aide de la vis. Serrez la vis qui n'a pas été entièrement serrée à l'étape 9.

## **Étape 27**

Ajustement de la porte

### **Pour ajuster la hauteur verticale :**

Desserrez les vis « A » des deux charnières. Elles sont généralement dans des trous oblongs, ce qui vous permet de les régler de quelques millimètres vers le haut ou vers le bas. Puis resserrez-les.

### **Pour ajuster la profondeur :**

Desserrez la vis « B » et réglez la porte.

### **Pour ajuster d'un côté à l'autre :**

Desserrez la vis « C » sur les DEUX charnières et serrez « B » pour déplacer la porte vers l'extérieur. Desserrez la vis « B » et serrez la vis « C » pour déplacer la porte vers l'intérieur.

## **Page 38**

### **CHARGES MAXIMALES**

Ce meuble a été conçu pour supporter les charges maximales indiquées. En excédant ces limites de charge, le meuble pourrait devenir instable, s'effondrer, et/ou causer des blessures graves.

**AVERTISSEMENT :** Risque de blessure corporelle - ne pas placer une télévision sur ce meuble. Ce meuble n'est pas approuvé pour une utilisation avec une télévision.

## **Page 39**

Enregistrez votre produit pour recevoir les éléments suivantes:

- \* Détails sur les nouvelles tendances - un aperçu sur les nouveautés
- \* Sondages - avoir une voix au sein de notre communauté
- \* Offres exclusives et codes promo
- \* Service de pièces de rechange rapide et facile

Pour enregistrer votre produit, visitez [systembuild.com](http://systembuild.com)

5 Étoiles

Visitez le site Web de votre détaillant local, évaluez votre produit acheté et laissez-nous quelques commentaires !

Nous tenons à offrir un grand "Merci" à tous nos clients pour avoir pris le temps d'assembler ce produit "Systembuild", et de nous donner vos commentaires précieux.

Merci

[littleseedskids.com](http://littleseedskids.com)